

# Hydraulic motors with Dual shaft type MRB...

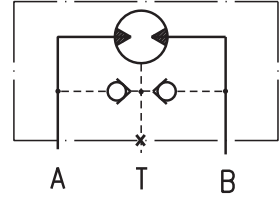

## OPTIONS

- » Model- Spool valve, roll-gerotor;
- » Dual shaft;
- » Oval flange;
- » Side port;
- » Straight shafts;
- » BSPP ports;
- » Other special features.

## APPLICATION

- » Conveyors;
- » Feeding mechanism of robots and manipulators;
- » Metal working machines;
- » Textile machines;
- » Agricultural machines;
- » Food industries;
- » Mining machinery etc.

## OUTLINE DIMENSINS REFERENCE

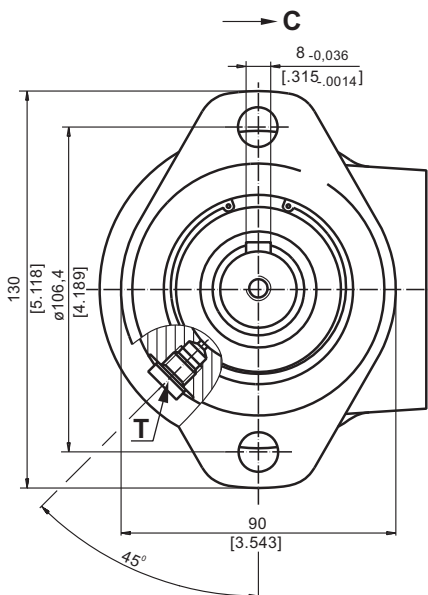
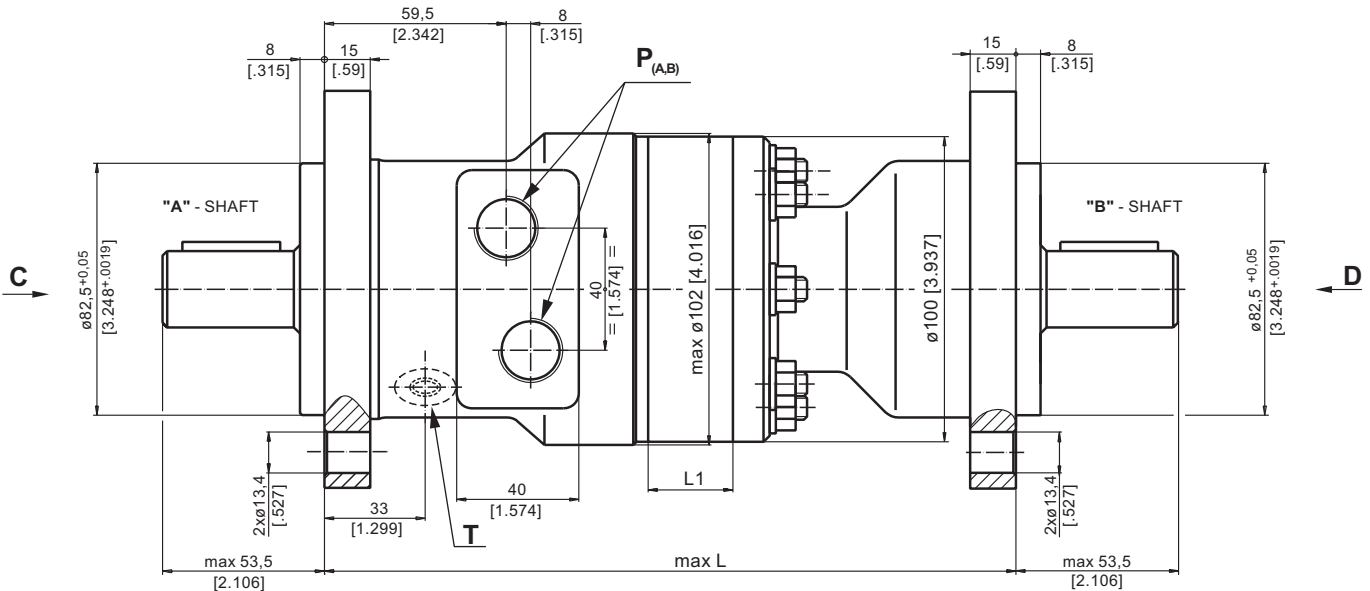

Type	L, mm [in]	L <sub>1</sub> , mm[in]
MRB 50	208,0 [8.19]	9,0 [.35]
MRB 80	213,0 [8.39]	14,0 [.55]
MRB 100	216,0 [8.50]	17,4 [.69]
MRB 125	220,5 [8.68]	21,8 [.86]
MRB 160	226,5 [8.92]	27,8 [1.09]
MRB 200	233,5 [9.19]	34,8 [1.37]
MRB 250	242,5 [9.55]	43,5 [1.71]
MRB 315	253,5 [9.98]	54,8 [2.16]
MRB 400	268,0 [10.55]	69,4 [2.73]

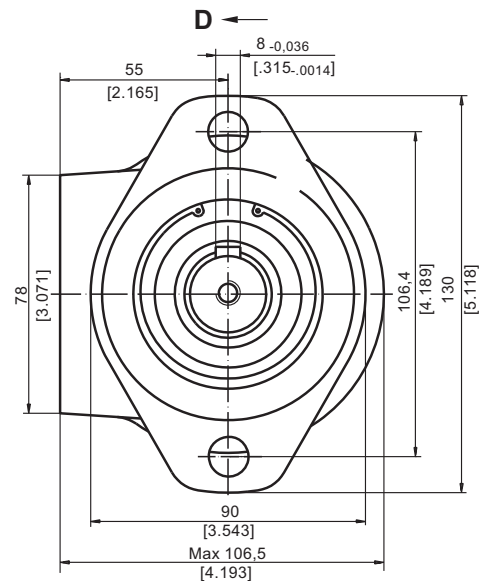

P<sub>(A,B)</sub>: 2xG1/2 - 18 mm [.71 in] depth  
 T : G1/8 - 9 mm [.35 in] depth (plugged)



## SPECIFICATION DATA

Type	MRB 50 C/C	MRB 80 C/C	MRB 100 C/C	MRB 125 C/C	MRB 160 C/C	MRB 200 C/C	MRB 250 C/C	MRB 315 C/C	MRB 400 C/C
<b>Displacement, cm<sup>3</sup>/rev [in<sup>3</sup>/rev]</b>	51,5[3.14]	80,3[4.9]	99,8[6.09]	125,7[7.67]	159,6[9.74]	199,8[12.19]	250,1[15.26]	315,7[19.26]	397 [24.4]
<b>Max. Speed,</b>									
cont.	775	750	600	475	375	300	240	190	150
<b>RPM</b>									
int.*	970	940	750	600	470	375	300	240	190
<b>Max. Torque,</b>									
cont.	10 [885]	19,5 [1725]	24 [2125]	30 [2655]	30 [2655]	30 [2655]	30 [2655]	30 [2655]	30 [2655]
<b>daNm [lb-in]</b>									
int.*	13 [1150]	22 [1947]	28 [2480]	34 [3010]	39 [3450]	39 [3450]	38 [3360]	42 [3720]	43 [3805]
<b>Max. Torque "A" Shaft,</b>									
cont.	8 [710]	11,5 [1000]	12 [1060]	20 [1770]	20 [1770]	20 [1770]	20 [1770]	20 [1770]	20 [1770]
<b>daNm [lb-in]</b>									
int.*	9,5 [840]	13 [1150]	14 [1240]	23 [2035]	23 [2035]	23 [2035]	23 [2035]	23 [2035]	23 [2035]
<b>Max. Torque "B" Shaft,</b>									
cont.	4 [355]	11,5 [1000]	12 [1060]	20 [1770]	20 [1770]	20 [1770]	20 [1770]	20 [1770]	20 [1770]
<b>daNm [lb-in]</b>									
int.*	5 [440]	13 [1150]	14 [1240]	23 [2035]	23 [2035]	23 [2035]	23 [2035]	23 [2035]	23 [2035]
<b>Max. Output,</b>									
cont.	7 [9.5]	12,5 [17]	13 [1150]	12,5 [17]	10 [13.4]	8 [10.7]	6 [8.0]	5 [6.7]	4 [5.4]
<b>[kW] [HP]</b>									
int.*	8,5 [11.9]	15 [20.1]	15 [20.1]	14,5	12,5 [17]	10 [13.4]	8 [10.7]	6,5 [8.7]	6 [8.0]
<b>Max. Pressure Drop,</b>									
cont.	140 [2030]	175 [2540]	175 [2540]	175 [2540]	130 [1885]	110 [1600]	80 [1160]	70 [1020]	55 [800]
<b>bar [PSI]</b>									
int.*	175 [2540]	200 [2900]	200 [2900]	200 [2900]	175 [2540]	140 [2030]	110 [1600]	100 [1450]	80 [1160]
<b>Max. Oil Flow,</b>									
cont.	40 [10.5]	60 [15.9]	60 [15.9]	60 [15.9]	60 [15.9]	60 [15.9]	60 [15.9]	60 [15.9]	60 [15.9]
<b>lpm [GPM]</b>									
int.*	50 [13.2]	75 [18.5]	75 [18.5]	75 [18.5]	75 [18.5]	75 [18.5]	75 [18.5]	75 [18.5]	75 [18.5]
<b>Max. Return</b>									
cont. 0 - 100 RPM	75 [1090]	75 [1090]	75 [1090]	75 [1090]	75 [1090]	75 [1090]	75 [1090]	75 [1090]	75 [1090]
<b>Pressure without</b>									
cont. 100-200 RPM	50 [730]	50 [730]	50 [730]	50 [730]	50 [730]	50 [730]	50 [730]	50 [730]	50 [730]
<b>Drain Line, bar [PSI]</b>									
cont. 200-500 RPM	20 [290]	20 [290]	20 [290]	20 [290]	20 [290]	20 [290]	20 [290]	20 [290]	20 [290]
int.* 0 - max RPM	75 [1090]	75 [1090]	75 [1090]	75 [1090]	75 [1090]	75 [1090]	75 [1090]	75 [1090]	75 [1090]

\* Intermittent operation: the permissible values may occur for max. 10% of every minute.

- Intermittent speed and intermittent pressure must not occur simultaneously.
- Recommended filtration is per ISO cleanliness code 20/16. A nominal filtration of 25 micron or better.
- Recommend using a premium quality, anti-wear type mineral based hydraulic oil HLP(DIN51524) or HM ( ISO 6743/4).  
If using synthetic fluids consult the factory for alternative seal materials.
- Recommended minimum oil viscosity 13 mm<sup>2</sup>/s [70 SUS] at 50°C [122°F].
- Recommended maximum system operating temperature is 82°C [180°F].
- To assure optimum motor life fill with fluid prior to loading and run at moderate load and speed for 10-15 minutes.

**SHAFT EXTENSIONS**

**C** -  $\varnothing 25$  straight, Parallel key A8x7x30 DIN 6885  
Max. Torque 34 daNm [3010 lb-in]

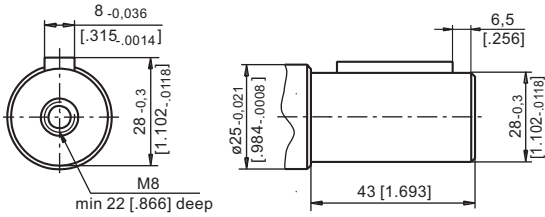

**SH** - 1" splined, BS 2059 (SAE 6B)  
Max. Torque 40 daNm [3540 lb-in]

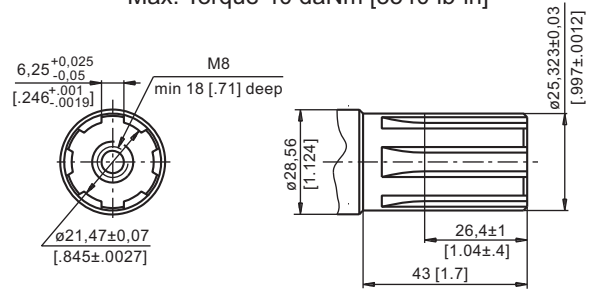

**PERMISSIBLE SHAFT LOADS**

The load diagrams are valid for an average bearings life of 1600 hrs at 200 r.p.m. with mineral base lubricating containing antiwear additives (ref.ISO 281 (3.3)standard).

The "A" curve gives the maximum static load affordable by the bearings.

The "B" curve gives the radial load top limit without axial load of 200 daN.

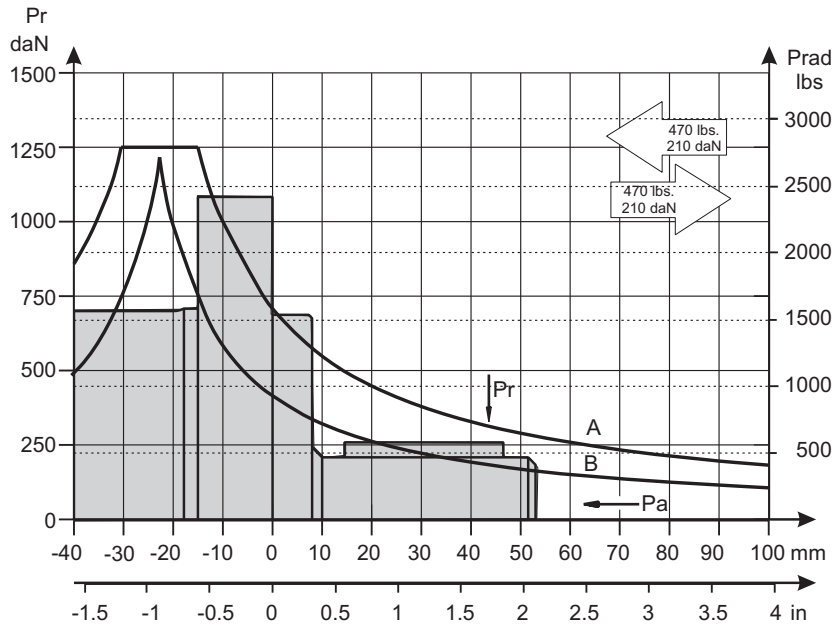

**ORDER CODE**

1	2	3	4	5
MRB		/		

**Pos.1 - Displacement code**

<b>50</b>	- 51,5 cm <sup>3</sup> /rev [3.14 in <sup>3</sup> /rev]
<b>80</b>	- 80,3 cm <sup>3</sup> /rev [4.90 in <sup>3</sup> /rev]
<b>100</b>	- 99,8 cm <sup>3</sup> /rev [6.09 in <sup>3</sup> /rev]
<b>125</b>	- 125,7 cm <sup>3</sup> /rev [7.67 in <sup>3</sup> /rev]
<b>160</b>	- 159,6 cm <sup>3</sup> /rev [9.74 in <sup>3</sup> /rev]
<b>200</b>	- 199,8 cm <sup>3</sup> /rev [12.19 in <sup>3</sup> /rev]
<b>250</b>	- 250,1 cm <sup>3</sup> /rev [15.26 in <sup>3</sup> /rev]
<b>315</b>	- 315,7 cm <sup>3</sup> /rev [19.26 in <sup>3</sup> /rev]
<b>400</b>	- 397,0 cm <sup>3</sup> /rev [24.40 in <sup>3</sup> /rev]

**Pos.2 - "A" Shaft Extensions\***

<b>C</b>	- $\varnothing 25$ straight, Parallel key A8x7x30 DIN6885
<b>SH</b>	- 1" splined, BS 2059 (SAE 6B)

**Pos.3 - "B" Shaft Extensions\***

<b>C</b>	- $\varnothing 25$ straight, Parallel key A8x7x30 DIN6885
<b>SH</b>	- 1" splined, BS 2059 (SAE 6B)

**Pos.4 - Special Features (see page 119)**

**Pos.5 - Design Series**

omit - Factory specified

**NOTES:** \* For other shaft extensions please contact with "M+S Hydraulic".  
\*\* Color at customer's request.

The hydraulic motors are manganophosphatized as standard.

# MOTOR SPECIAL FEATURES

Special Feature Description	Order Code	Motor type												
		MM	MP	MP(W)N, MRN	MPW	MR	MRB	SP, SR	PL, RL	PK, RK	PKQ	RW	MH	HW
Speed Sensor*	RS	O	O	-	-	O	-	-	-	-	-	-	O	-
Tacho connection	T	-	-	-	-	O	-	-	-	-	-	-	O	-
Low Leakage	LL	O	O	-	O	O	-	-	O	O	O	O	O	O
Low Speed Valving	LSV	-	-	-	O	O	-	-	-	-	O	O	O	O
Free Running	FR	O	O	-	-	O	-	-	O	O	-	O	O	O
Reverse Rotation	R	O	O	O	O	O	O	O	O	O	O	O	O	O
Paint**	P	O	O	O	O	O	O	O	O	O	O	O	O	O
Corrosion Protected Paint***	PC	O	O	O	O	O	O	O	O	O	O	O	O	O
Special Paint***	PS	O	O	O	O	O	O	-	O	O	O	O	O	O
	PCS	O	O	O	O	O	O	-	O	O	O	O	O	O
Check Valves		S	S****	S	S****	S****	S	S	S	S	S	S	S****	S

<b>O</b>	Optional
<b>-</b>	Not applicable
<b>S</b>	Standard

\* For sensor ordering see pages 120÷121.

\*\* Colour at customer's request.

\*\*\* Non painted feeding surfaces, colour at customer's request.

\*\*\*\* Without check valves for "U" shaft seal versions.

# MOTORS WITH SPEED SENSOR

## MM...RS

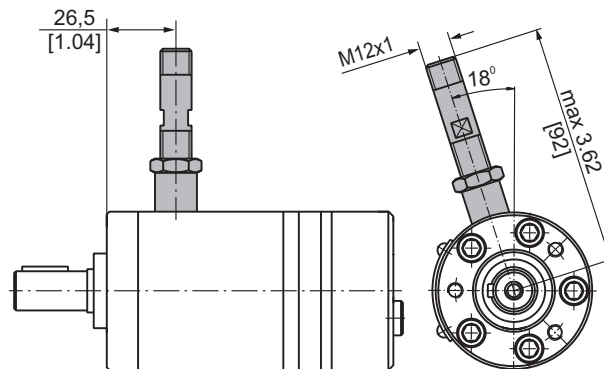

## MP...RS and MR...RS

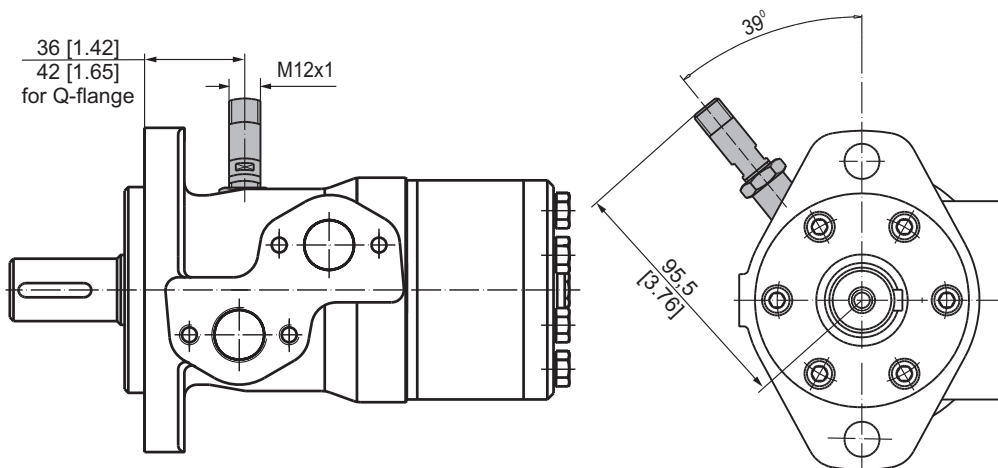

## MH...RS

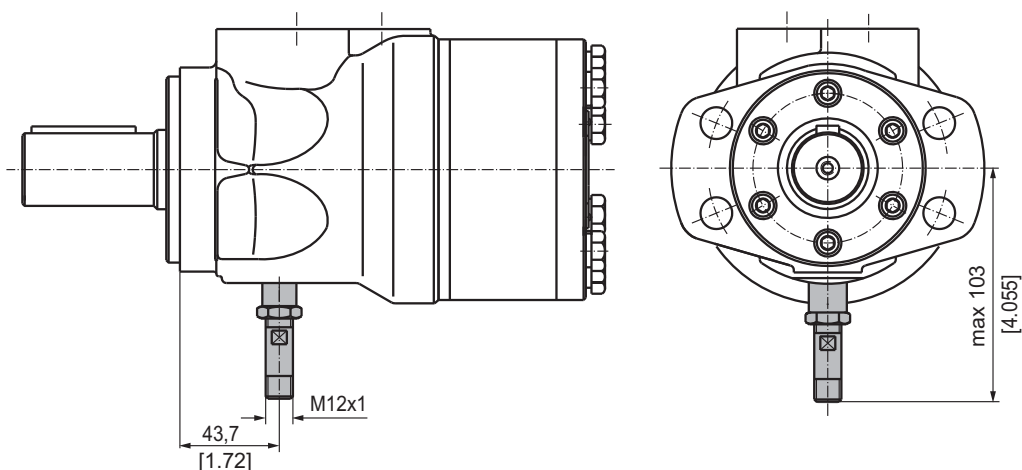

**TECHNICAL DATA OF THE SPEED SENSOR**

**Technical data**

Frequency range	0...15 000 Hz
Output	PNP, NPN
Power supply	10...36 VDC
Current input	20 mA (@24 VDC)
Ambient Temperature	-40...+125°C [-40...+257°F]
Protection	IP 67
Plug connector	M12-Series
Mounting principle	ISO 6149

**Output signal**

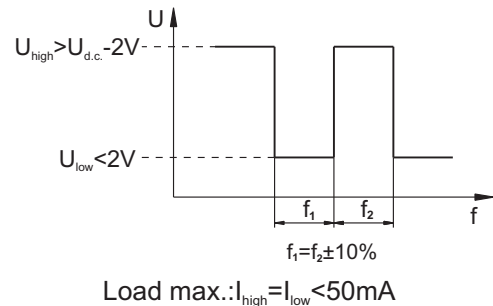

Motor type	MM	MP	MR	MH
Pulses per revolution	30	36	36	42

**Wiring diagrams**

**PNP**

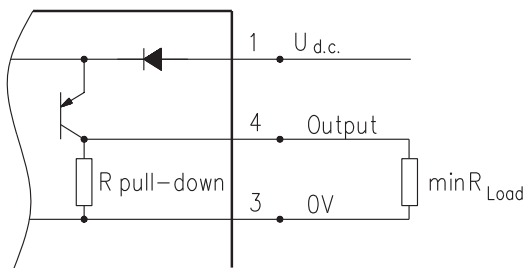

**NPN**

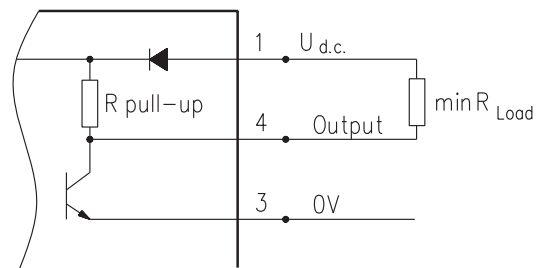

$$R_{Load} [\text{k}\Omega] = U_{d.c.} [\text{V}] / I_{max} [\text{mA}]$$

**Stick type**

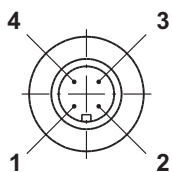

Terminal No.	Connection	Cable Output
1	$U_{d.c.}$	Brown
2	No connection	White
3	0V	Blue
4	Output signal	Black

**Order Code for Speed Sensor**

Sensor Code	Output type	Electric connection
<b>RSN</b>	NPN	Connector BINDER 713 series
<b>RSP</b>	PNP	Connector BINDER 713 series
<b>RSNL5</b>	NPN	Cable output 3x0,25; 5 m [196 in] long
<b>RSPL5</b>	PNP	Cable output 3x0,25; 5 m [196 in] long

**NOTE:** \*- The speed sensor is not fitted at the factory, but is supplied in a plastic bag with the motor. For installation see enclosed instructions.

# APPLICATION CALCULATION

## VEHICLE DRIVE CALCULATIONS

### 1. Motor speed: n, RPM

$$n = \frac{2,65 \times v_{km} \times i}{R_m} \quad n = \frac{168 \times v_{mi} \times i}{R_m}$$

$v_{km}$ - vehicle speed, km/h;

$v_{mi}$ - vehicle speed, mil/h;

$R_m$ - wheel rolling radius, m;

$R_m$ - wheel rolling radius, in;

$i$ - gear ratio between motor and wheels.

If no gearbox, use  $i=1$ .

### 2. Rolling resistance: RR, daN [lbs]

The resistance force resulted in wheels contact with different surfaces:

$$RR = G \times \rho$$

$G$ - total weight loaded on vehicle, daN [lbs];

$\rho$ - rolling resistance coefficient (Table 1).

Table 1

Rolling resistance coefficient In case of rubber tire rolling on different surfaces	
Surface	$\rho$
Concrete- faultless	0.010
Concrete- good	0.015
Concrete- bad	0.020
Asphalt- faultless	0.012
Asphalt- good	0.017
Asphalt- bad	0.022
Macadam- faultless	0.015
Macadam- good	0.022
Macadam- bad	0.037
Snow- 5 cm	0.025
Snow- 10 cm	0.037
Polluted covering- smooth	0.025
Polluted covering- sandy	0.040
Mud	0.037÷0.150
Sand- Gravel	0.060÷0.150
Sand- loose	0.160÷0.300

### 3. Grade resistance: GR, daN [lbs]

$$GR = G \times (\sin \alpha + \rho \times \cos \alpha)$$

$\alpha$ - gradient negotiation angle (Table 2)

Table 2

Grade %	$\alpha$ Degrees	Grade %	$\alpha$ Degrees
1%	0° 35'	12%	6° 5'
2%	1° 9'	15%	8° 31'
5%	2° 51'	20%	11° 19'
6%	3° 26'	25%	14° 3'
8%	4° 35'	32%	18°
10%	5° 43'	60%	31°

### 4. Acceleration force: FA, daN [lbs]

Force  $FA$  necessary for acceleration from 0 to maximum speed  $v$  and time  $t$  can be calculated with a formula:

$$FA = \frac{v_{km} \times G}{3,6 \times t}, [daN] \quad FA = \frac{v_{mi} \times G}{22 \times t}, [lbs];$$

$FA$ - acceleration force, daN [lbs];

$t$ - time, [s].

### 5. Tractive effort: DP, daN [lbs]

Tractive effort  $DP$  is the additional force of trailer. This value will be established as follows:

-acc.to constructor's assessment;

-as calculating forces in items 2, 3 and 4 of trailer; the calculated sum corresponds to the tractive effort requested.

### 6. Total tractive effort: TE, daN [lbs]

Total tractive effort  $TE$  is total effort necessary for vehicle motion; that the sum of forces calculated in items from 2 to 5 and increased with 10 % because of air resistance.

$$TE = 1,1 \times (RR + GR + FA + DP)$$

$RR$ - force acquired to overcome the rolling resistance;

$GR$ - force acquired to slope upwards;

$FA$ - force acquired to accelerate (acceleration force);

$DP$ - additional tractive effort (trailer).

### 7. Motor Torque moment: M, daNm [in-lb]

Necessary torque moment for every hydraulic motor:

$$M = \frac{TE \times R_{in}[R_m]}{N \times i \times \eta_m}$$

$N$ - motor numbers;

$\eta_m$ -mechanical gear efficiency (if it is available).

### 8. Cohesion between tire and road covering: $M_w$ , daNm [in-lb]

$$M_w = \frac{G_w \times f \times R_{in}[R_m]}{i \times \eta_m}$$

To avoid wheel slipping, the following condition should be observed  $M_w > M$

$f$  - frictional factor;

$G_w$ - total weight over the wheels, daN [lbs].

Table 3

Surface	Frictional factor $f$
Steel on steel	0.15 ÷ 0.20
Rubber tire on polluted surface	0.5 ÷ 0.7
Rubber tire on asphalt	0.8 ÷ 1.0
Rubber tire on concrete	0.8 ÷ 1.0
Rubber tire on grass	0.4

**9.Radial motor loading:  $P_{rad}$ , daN [lbs]**

When motor is used for vehicle motion with wheels mounted directly on motor shaft, the total radial loading of motor shaft  $P_{rad}$  is a sum of motion force and weight force acting on one wheel.

- $G_w$  - Weight held by wheel;
- $P_{rad}$  - Total radial loading of motor shaft;
- $M/R$  - Motion force.

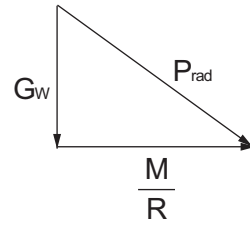

$$P_{rad} = \sqrt{G_w^2 + \left(\frac{M}{R}\right)^2}$$

In accordance with calculated loadings the suitable motor from the catalogue is selected.

**DRAINAGE SPACE AND DRAINAGE PRESSURE**

Advantages in oil drainage from drain space: Cleaning; Cooling and Seal lifetime prolonging.

