

HYDRAULIC DISC BRAKES LB, LBS, LBV- Wet



APPLICATION

- » Heavy Duty machinery
- » Wheel drives
- » Material handling
- » Mining
- » Agricultural machines
- » Conveyors
- » Door openers and swing drives etc.



GENERAL

| | |
|--|--|
| Fluid type | Mineral based- HLP(DIN 51524) or HM(ISO 6743/4) |
| Temperature range, °C [°F] | -40÷140 [-40÷284] |
| Viscosity range, mm²/s | 20÷75 [98÷347] |
| Filtration | ISO code 20/16 (nominal filtration of 25 microns) |
| Maintenance | Changed after the first 50-100 h, then after every 500-1500 h. |

CONTENTS

| | |
|---|-----|
| Hydraulic Disc Brake for MP, MR and MS Motors type LB/288 | 4÷5 |
| Hydraulic Disc Brake for MSS and MSV type LBS(V)/289 | 6 |
| Hydraulic Disc Brake for MSS and MSV type LBS(V)/290 | 7 |
| Output Shafts for LBS(LBV)/289, 290 | 8 |
| Specification data for LBS(LBV)/289, 290 | 8 |
| Load curve for LBS(LBV)/289, 290 | 8 |
| Internal Spline data for .../289,290 and .../314,315..... | 9 |
| Order code for LB/288,LBS(LBV)/289, 290 | 9 |
| Hydraulic Disc Brake for MTS and MTV type LBS(LBV)/314 | 10 |
| Hydraulic Disc Brake for MTS and MTV type LBS(LBV)/315 | 11 |
| Specification data for LBS(LBV)/314, 315 | 12 |
| Load curve for LBS(LBV)/314, 315 | 12 |
| Output Shafts for LBS(LBV)/314, 315 | 13 |
| Order code for LBS(LBV)/314, 315 | 13 |
| Hydraulic Disc Brake for MVS type LBS/313 | 14 |
| Load curve for LBS/313 | 14 |
| Hydraulic Disc Brake for MVS type LBS/316 | 15 |
| Load curve for LBS/316 | 15 |
| Specification data for LBS/313, 316..... | 16 |
| Output Shafts for LBS/313, 316 | 16 |
| Internal Spline data for LBS/313, 316 | 17 |
| Order code for LBS/313, 316 | 17 |

LB, LBS

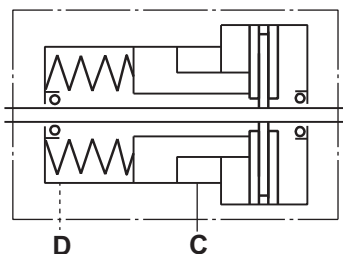

LBV

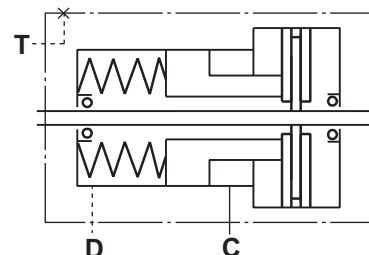

HYDRAULIC DISC BRAKE FOR FLANGE ATTACHMENT TO MP, MR AND MS HYDRAULIC MOTORS

TYPE LB/288

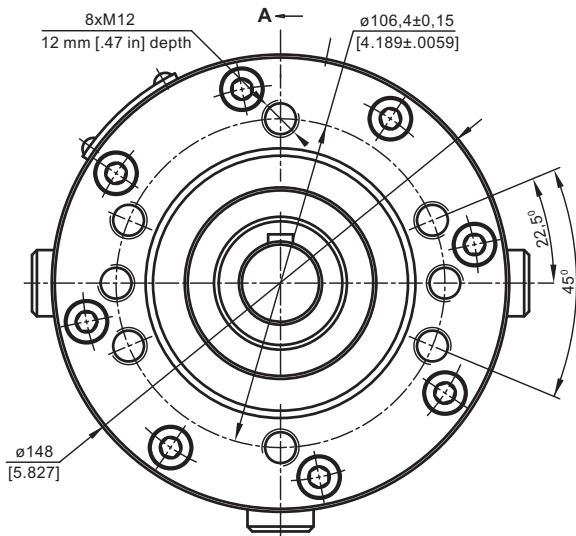
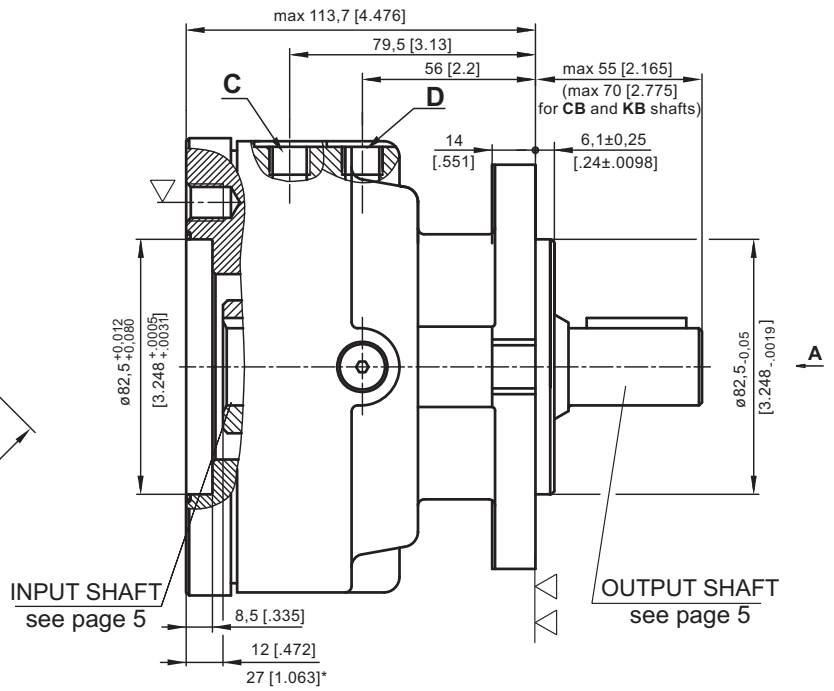
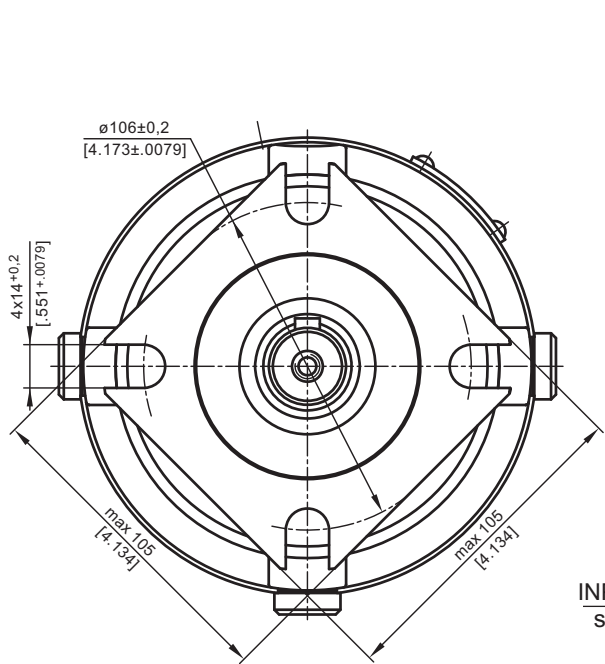

- ▽ - Place for attachment (tightening torque for screw M12x30 - 8.8 DIN 912 - 7 daNm [620 lb-in])
- ▽▽ - Place for attachment

- C:** Brake release Port - G $\frac{1}{4}$, 9 mm [0.35 in] depth
- D:** Drainage tap - G $\frac{1}{4}$, 9 mm [0.35 in] depth

* - For Input Shaft Hole Versions **SH** and **SB**.

LOAD CURVE

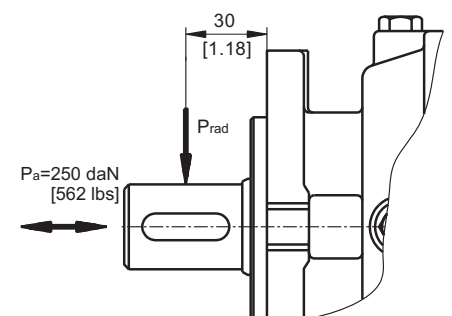
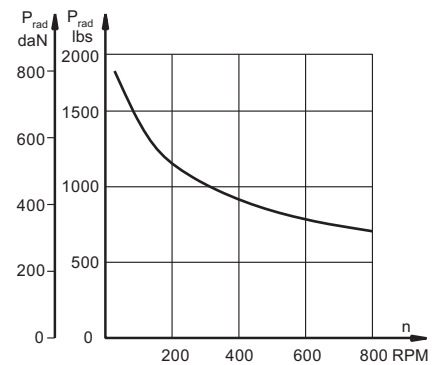

SPECIFICATION DATA

| Description LB/288... | 7 | 14 | 21 | 32 | 43 | 63 |
|---|-----------------------|-------------------|-------------------|-------------------|-------------------|-------------------|
| *Min. Static Torque, daNm [lb-in] | 6-8 [531-708] | 13-15 [1150-1327] | 20-22 [1770-1947] | 31-34 [2743-3009] | 41-45 [3628-3982] | 61-64 [5399-5665] |
| Opening Pressure, min bar [PSI] | 4-5 [58-73] | 8-9 [116-130] | 12-13 [174-188] | 18-20 [260-290] | 24-26 [348-377] | 38-39 [550-565] |
| max | 300 [4350] | | | | | |
| Min. oil quantity for brake releasing, cm ³ [in ³] | 7 - 8 [0.427 - 0.488] | | | | | |
| Oil volume, cm ³ [in ³] | 50 - 120 [3.5 - 7.35] | | | | | |
| Max. Pressure in drain space, bar [PSI] | 0,5 [7.25] | | | | | |
| Weight, kg [lb] | 9 [19.8] | | | | | |

*Static torque is obtained at working pressure - 0 bar [0 PSI].

INPUT SHAFT HOLES

C

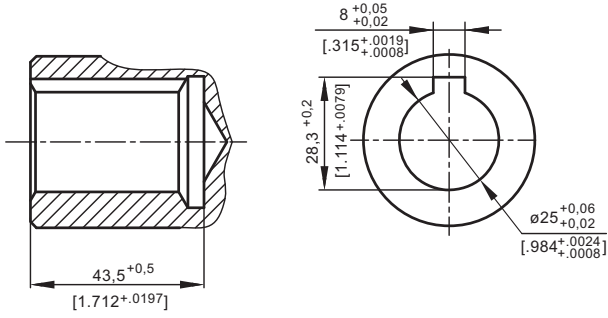

CO

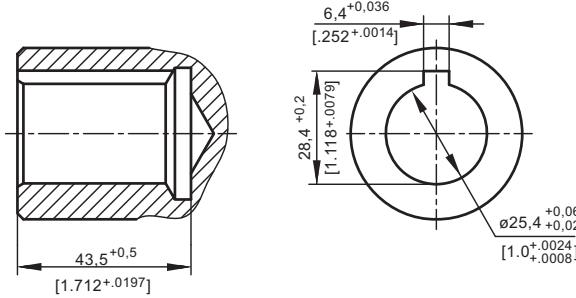

SH

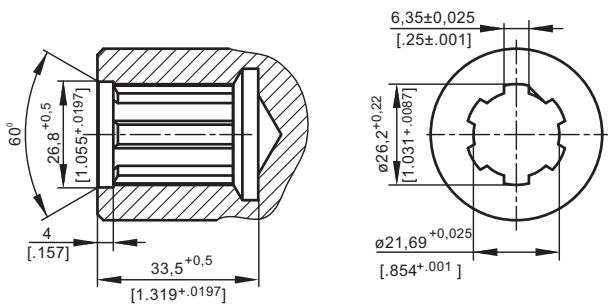

SB

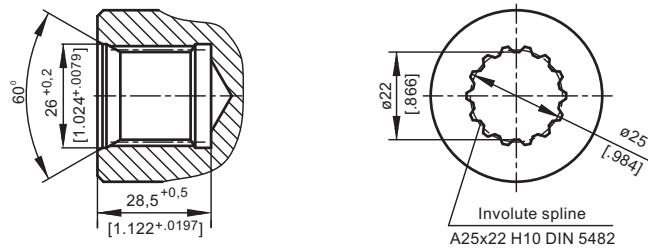

CB

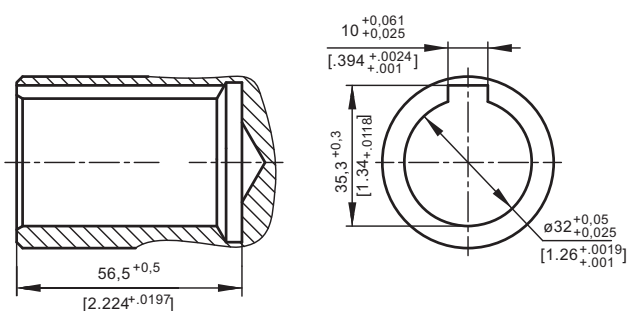

OUTPUT SHAFT EXTENSIONS

C - ø25 straight, Parallel key A8x7x32 DIN 6885
Max. Torque 34 daNm [3010 lb-in]

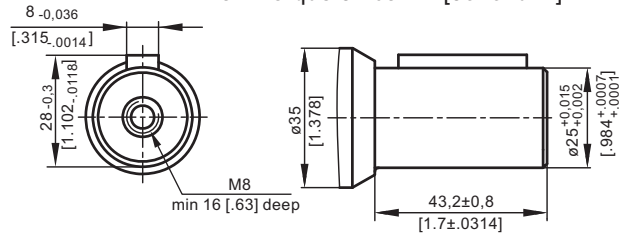

CO - ø1" straight, Parallel key 1/4"x1/4"x1/4" BS46
Max. Torque 34 daNm [3010 lb-in]

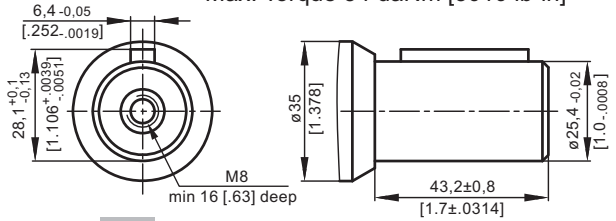

SH - splined, BS 2059 (SAE 6B)
Max. Torque 40 daNm [3540 lb-in]

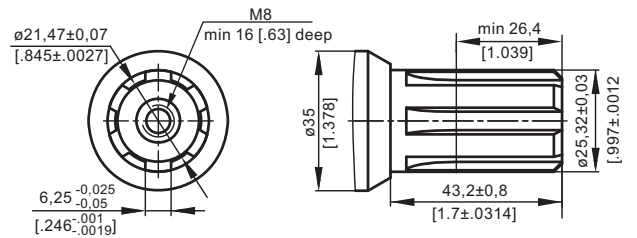

SA - splined, B25x22h9 DIN 5482
Max. Torque 40 daNm [3540 lb-in]

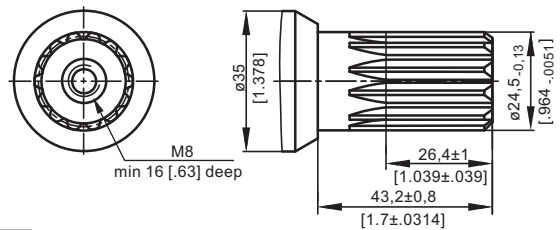

CB - ø32 straight, Parallel key A10x8x45 DIN 6885
Max. Torque 77 daNm [6815 lb-in]

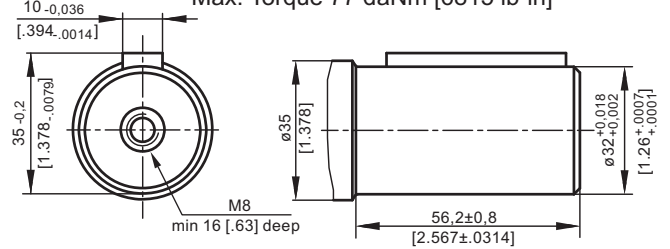

KB - tapered 1:10, Parallel key B6x6x20 DIN 6885
Max. Torque 95 daNm [8400 lb-in]

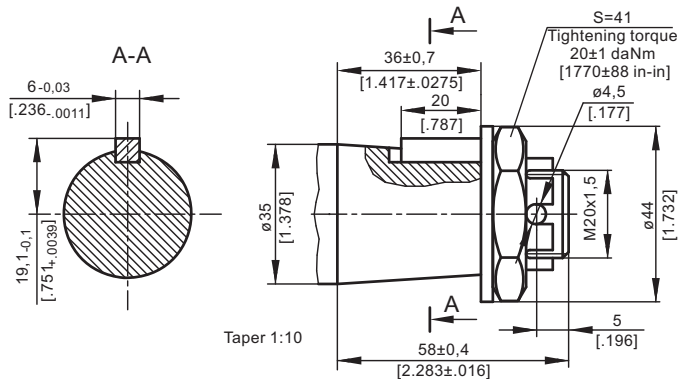

**HYDRAULIC DISC BRAKE FOR FLANGE ATTACHMENT
TO MSS AND MSV HYDRAULIC MOTORS**

TYPE LBS/289

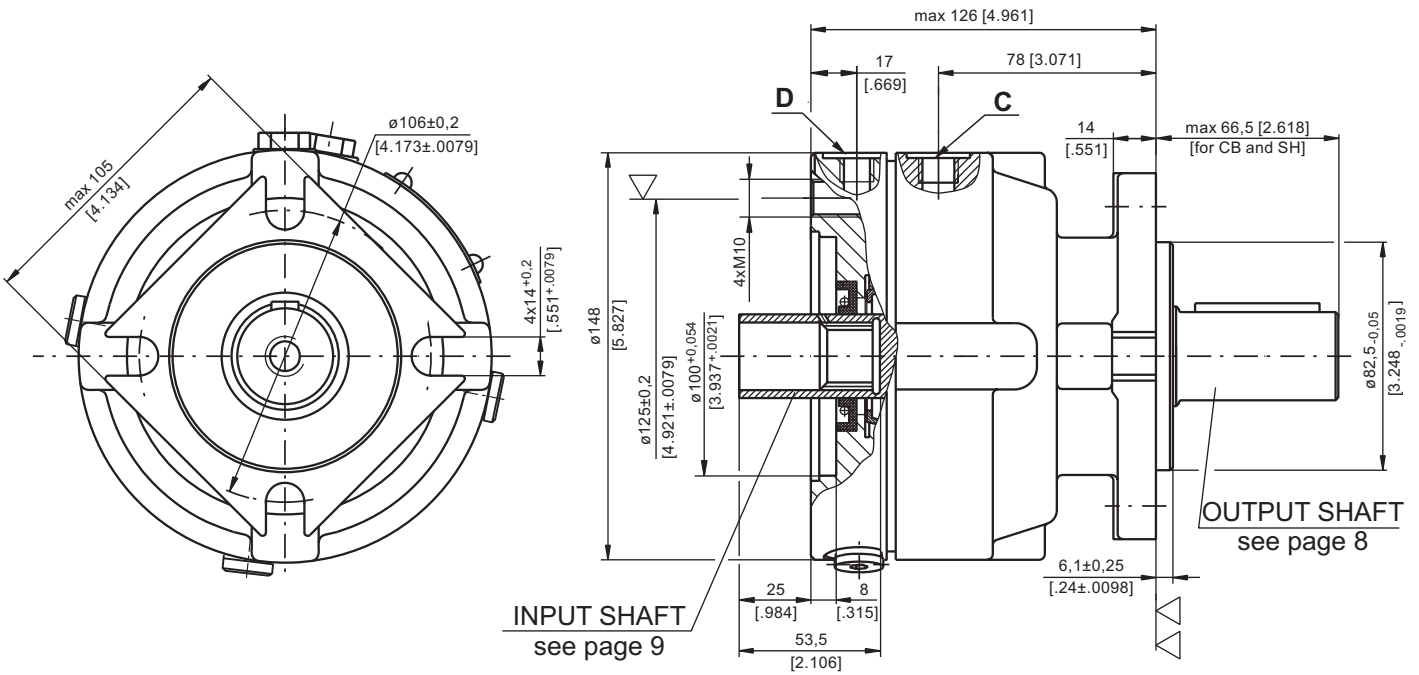

▽ - Place for attachment:

LBS - tightening torque for screw M10x35 - 8.8 DIN 912 - 5 daNm [440 lb-in]

LBV - tightening torque for screw M10xL - 12.9 DIN 931 - 6⁺¹ daNm [530⁺⁹⁰ lb-in]

▽▽ - Place for attachment



C: Brake release Port - G $\frac{1}{4}$, 9 mm [.35 in] depth

D: Drain plug for the Brake - G $\frac{1}{4}$, 9 mm [.35 in] depth

T: Drain plug for the Motor - G $\frac{1}{4}$, 9 mm [.35 in] depth

TYPE LBV/289

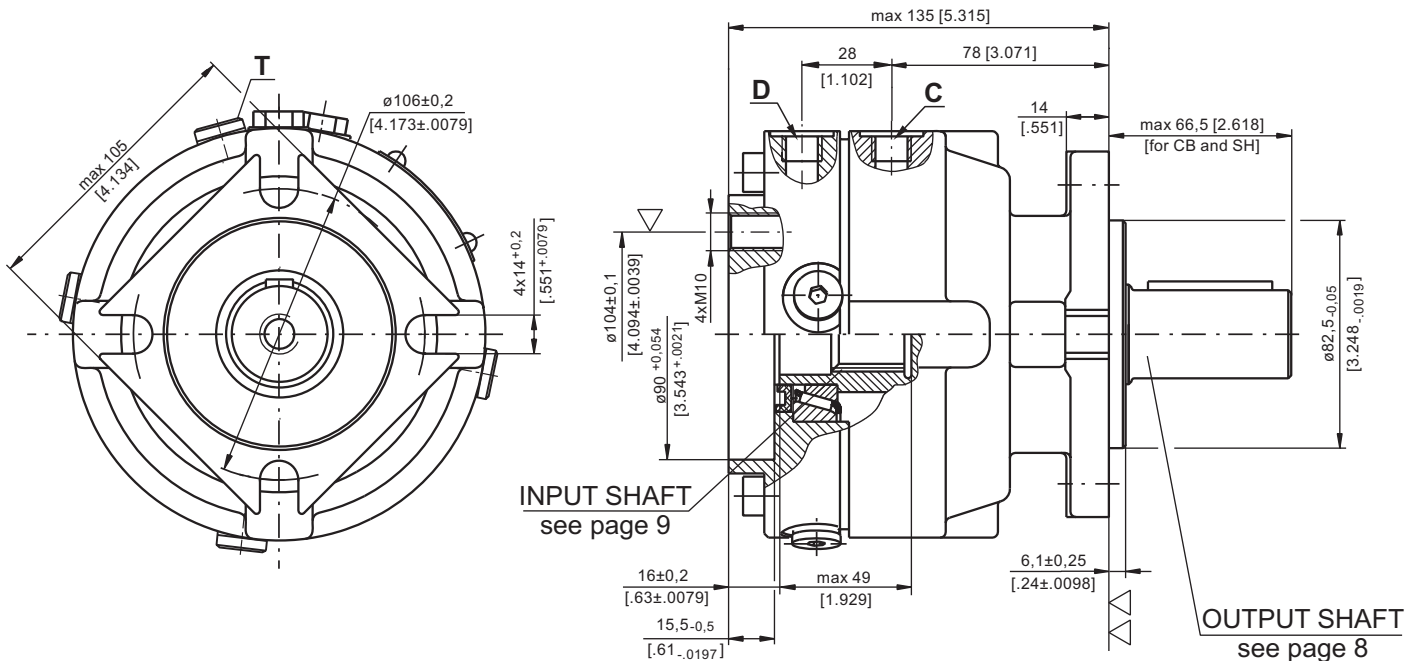

HYDRAULIC DISC BRAKE FOR FLANGE ATTACHMENT TO MSS AND MSV HYDRAULIC MOTORS

TYPE LBS/290

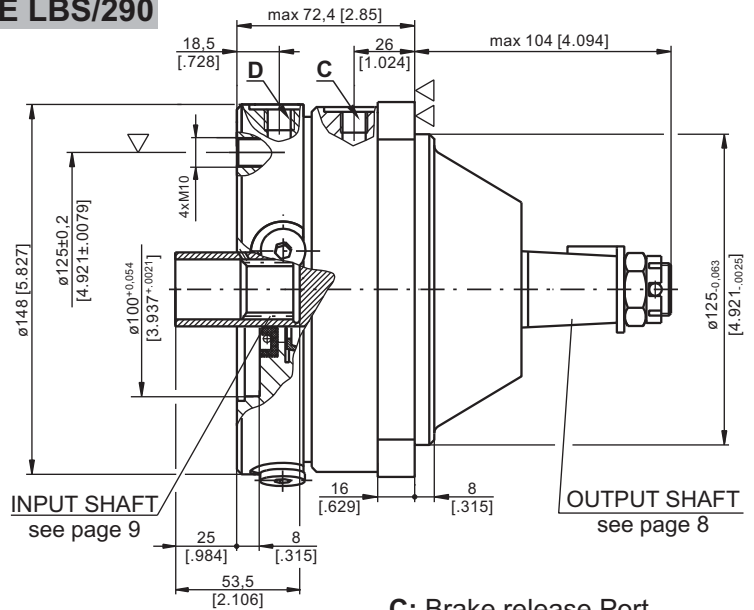
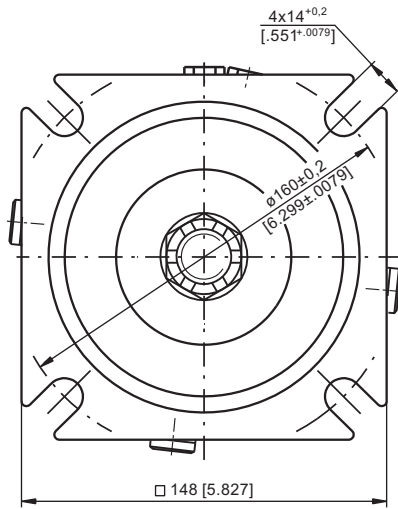

- ▽ - Place for attachment:
 LBS - tightening torque for screw M10x35 - 8.8 DIN 912 - 5 daNm [440 lb-in]
 LBV - tightening torque for screw M10xL - 12.9 DIN 931 - 6⁺ daNm [530⁹⁰ lb-in]
- ▽▽ - Place for attachment

- C:** Brake release Port
 - G¹/₄, 9 mm [.35 in] depth
- D:** Drain plug for the Brake
 - G¹/₄, 9 mm [.35 in] depth
- T:** Drain plug for the Motor
 - G¹/₄, 9 mm [.35 in] depth

TYPE LBV/290

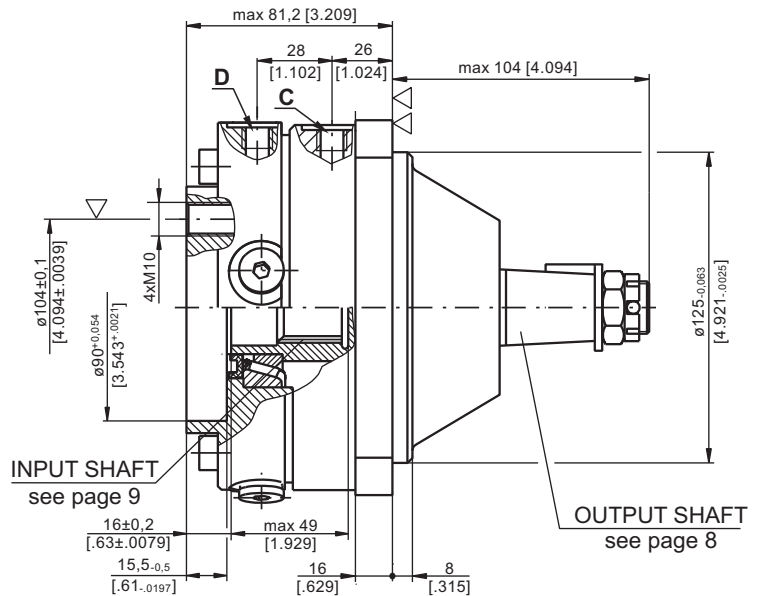
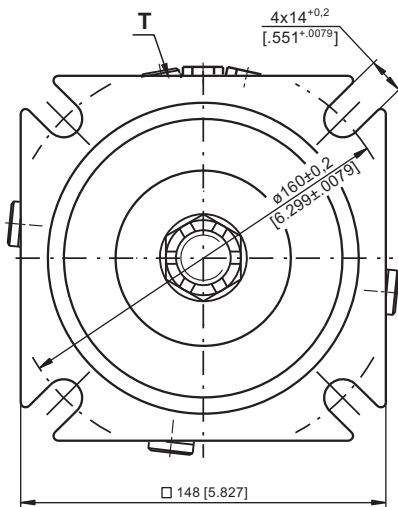

TYPE LBS/289(290)

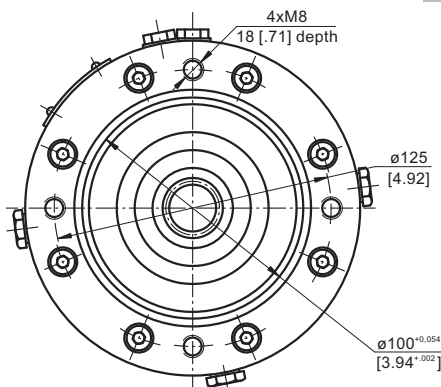

INPUT FACE For Versions 289 and 290

TYPE LBV/289(290)

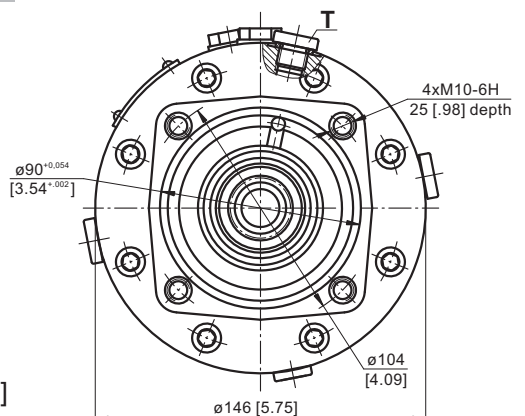

OUTPUT SHAFT EXTENSIONS

CB - $\phi 32$ straight, Parallel key A10x8x45 DIN 6885
Max. Torque 77 daNm [6815 lb-in]

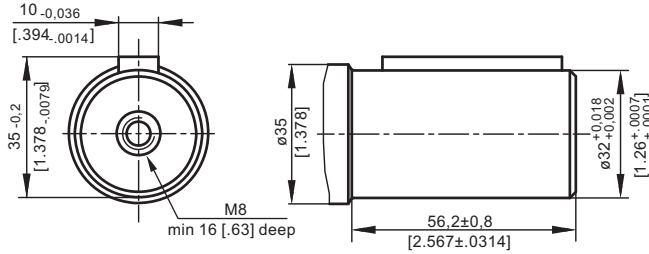

KB - tapered 1:10, Parallel key B6x6x20 DIN 6885
Max. Torque 95 daNm [8400 lb-in]

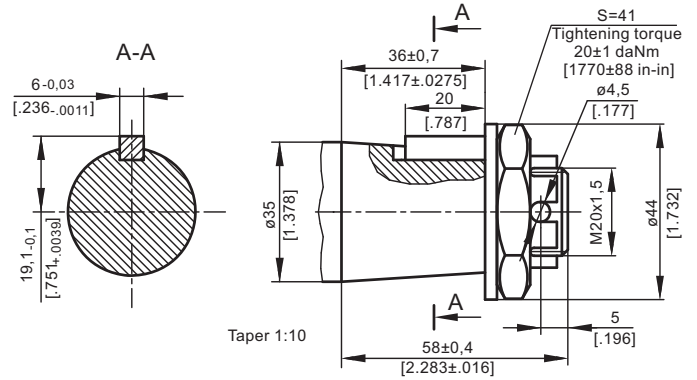

SPECIFICATION DATA

SH - $\phi 1\frac{1}{4}$ " splined 14T, DP12/24 ANS B92.1-1970
Max. Torque 95 daNm [8400 lb-in]

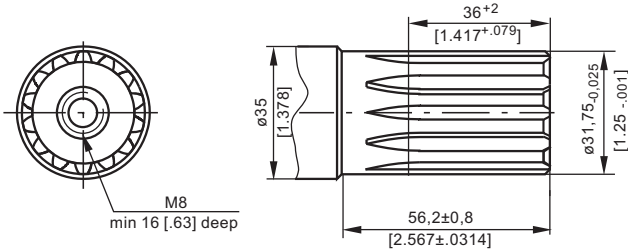

| Description LBS/289(290) LBV/289(290) | 21 | 32 | 43 | 63 |
|---|------------------------|----------------------|----------------------|----------------------|
| *Min. Static Torque, daNm [lb-in] | 20-22 [1770-1947] | 31-34 [2743-3009] | 41-45 [3628-3982] | 61-64 [5399-5665] |
| Opening Pressure, bar [PSI] | min [174-188] | 18-20 [260-290] | 24-26 [348-377] | 38-39 [550-565] |
| | max 300 [4350] | | | |
| Min. oil quantity for brake releasing cm ³ [in ³] | 7 - 8 [.427 - .488] | | | |
| Oil volume cm ³ [in ³] | 50 - 120 [3.05 - 7.35] | | | |
| Max. Pressure in drain space bar [PSI] | 5 [72] | | | |
| Weight kg [lb] | 9 [19.8] | | | |

*Static torque is obtained at working pressure - 0 bar [0 PSI].

LOAD CURVE

The curve applies to a B10 bearing life of 3000 hours at 200 RPM.

- 1: Pa < 350 daN [787 lbs]
- 2: Pa = 500 daN [1125 lbs]

LBS(V)/289

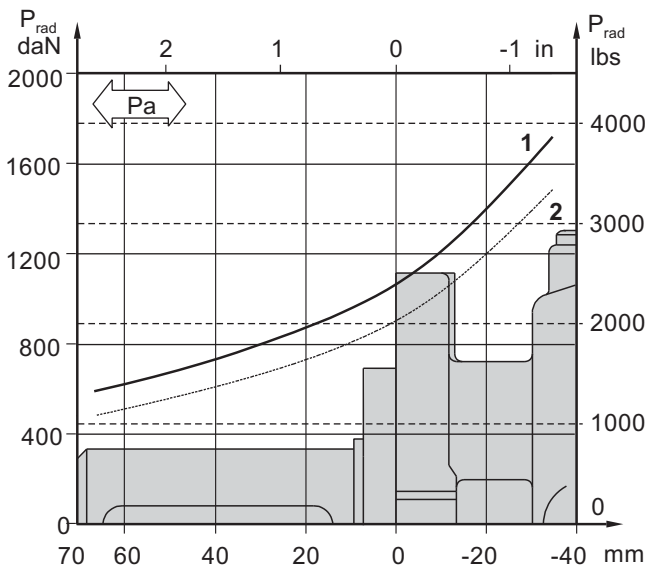

LBS(V)/290

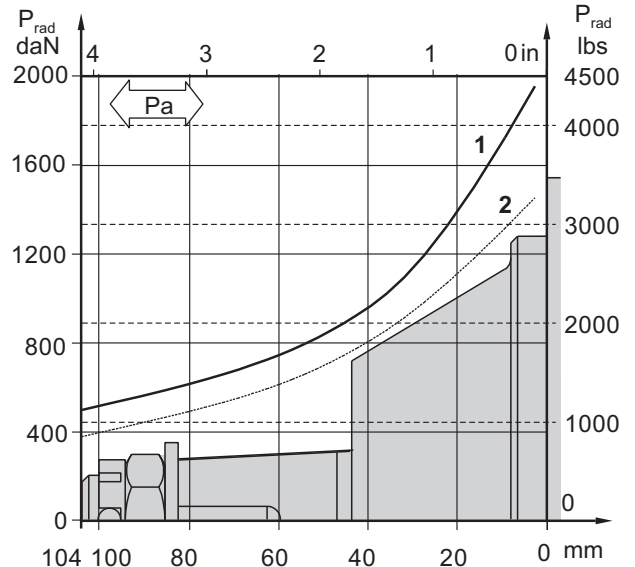

INTERNAL SPLINE DATA FOR THE ATTACHED COMPONENT

Standard ANS B92.1-1970, class 5

[m=2.1166]

| Fillet Root Side Fit | | LBS(V)/289 LBS(V)/290 | | LBS(V)/314 LBS(V)/315 | |
|-------------------------------|-----------------|--------------------------|---------------|--------------------------|---------------|
| | | mm | inch | mm | inch |
| Number of Teeth | z | 12 | 12 | 16 | 16 |
| Diametral Pitch | DP | 12/24 | 12/24 | 12/24 | 12/24 |
| Pressure Angle | | 30° | 30° | 30° | 30° |
| Pitch Dia. | D | 25,4 | 1 | 33,8656 | 1.3333 |
| Major Dia. | D _{ri} | 28,0 ^{-0,1} | 1.1 ± 1.098 | 38,4 ^{+0,4} | 1.5118±1.5275 |
| Minor Dia. | D _i | 23,0 ^{+0,033} | .907 ± .905 | 32,15 ^{+0,06} | 1.2657±1.2673 |
| Space Width [Circular] | Lo | 4,308±0,020 | .1704 ± .1688 | 4,516±0,037 | .1763±.1791 |
| Fillet Radius | R | 0,2 | .008 | 0,5 | .02 |
| Max. Measurement between Pins | L | 17,62 ^{+0,15} | .699 ± .694 | 26,9 ^{+0,10} | 1.063±1.059 |
| Pin Dia. | d | 4,835±0,001 | .19039±.19031 | 4,835±0,001 | .19026±.19034 |
| Corrected | x.m | +0,8 | +0,031 | +1,0 | +0,039 |

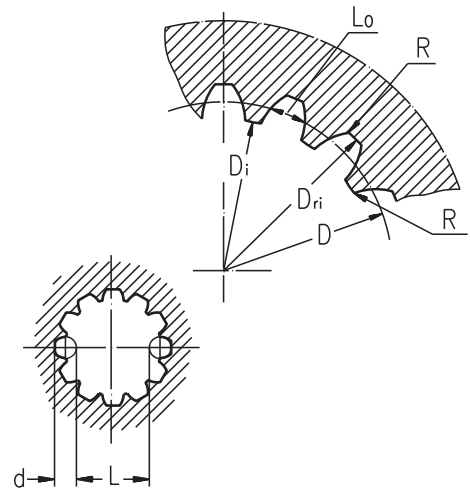

ORDER CODE - LB/288

| | | | | | |
|---------------|---|---|---|---|---|
| | 1 | 2 | 3 | 4 | 5 |
| LB/288 | | - | | | |

Pos.1 - Input Shaft Hole

C, CO, SH, CB, SB

Pos.2 - Static Torque code (See Specification data)

7, 14, 21, 32, 43, 63

Pos.3 - Output Shaft Extensions*

C - ø25 straight, Parallel key A8x7x32 DIN 6885

CO - ø1" straight, Parallel key ¼"x¼"x1¼" BS46

SH - ø25,32 splined BS 2059 (SAE 6B)

SA - ø24,5 splined B25x22 DIN 5482

CB - ø32 straight, Parallel key A10x8x45 DIN 6885

KB - ø35 tapered 1:10, Parallel key B6x6x20 DIN6885

Pos.4 - Option (Paint)**

omit - no Paint

P - Painted

PC - Corrosion Protected Paint

Pos.5 - Design Series

omit - Factory specified

ORDER CODE - LBS, LBV

| | | | | | | |
|-----------|---|---|---|---|---|---|
| | 1 | 2 | 3 | 4 | 5 | 6 |
| LB | | / | - | | | |

Pos.1 - Type

S - Disc Brake for short motor S- MSS

V - Disc Brake for very short motor V- MSV

Pos.2 - Design code

289 - for MSS and MSV Motors

290 - for MSS and MSV Motors (Wheel Mount)

Pos.3 - Static Torque code (See Specification data)

21, 32, 43, 63

Pos.4 - Output Shaft Extensions*

CB - ø32 straight, Parallel key A10x8x45 DIN 6885

KB - ø35 tapered 1:10, Parallel key B6x6x20 DIN6885

SH - ø1¼" splined 14T ANS B92.1-1970

Pos.5 - Option (Paint)**

omit - no Paint

P - Painted

PC - Corrosion Protected Paint

Pos.6 - Design Series

omit - Factory specified

NOTES:

* The permissible output torque for shafts must not be exceeded! For Max. Torque values see data on page 5 and 8.

** The color is by customer's request.

The Disc Brakes are mangano-phosphatized as standard.

ATTENTION:

- Hydraulic brake is delivered without oil (it is lubricated only).
- Hydraulic brake is filled through the drain port **D**. Space is filled with 50 ÷ 120 cm³ [3.05÷7.32 in³] mineral oil HLP (DIN 51524) or HM (ISO 6743/4). For LB/288 fill oil after hydraulic motor assembly.
- In all brakes, friction discs and separators should be lubricated.

**HYDRAULIC DISC BRAKES
FOR FLANGE ATTACHMENT TO MTS AND MTV HYDRAULIC MOTORS**

TYPE LBS/314

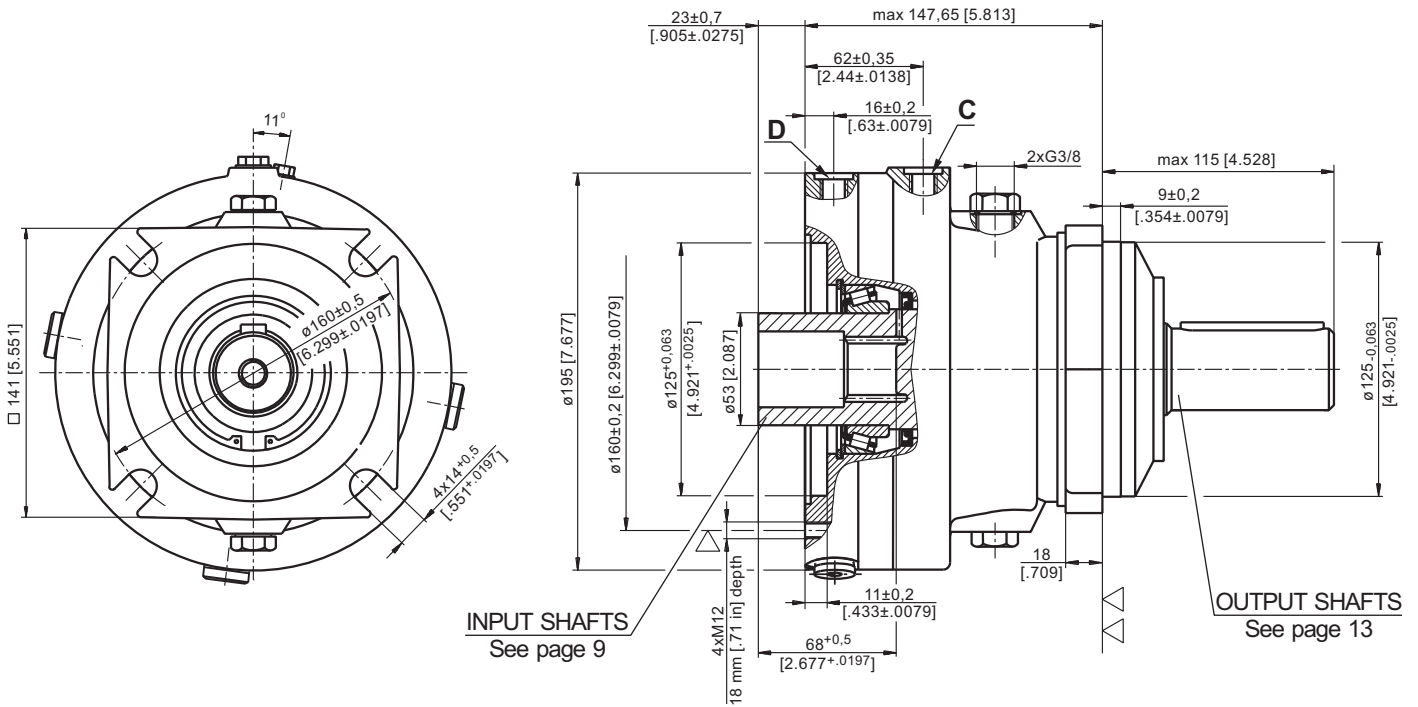

▽ - Place for attachment
(tightening torque for screw M12x30- 8.8 DIN 912,
7 daNm [620 lb-in])

C: Brake release Port - G $\frac{1}{4}$, 12 mm [.47 in] depth
D: Drainage tap - G $\frac{1}{4}$, 12 mm [.47 in] depth

▽▽ - Place for attachment

TYPE LBV/314

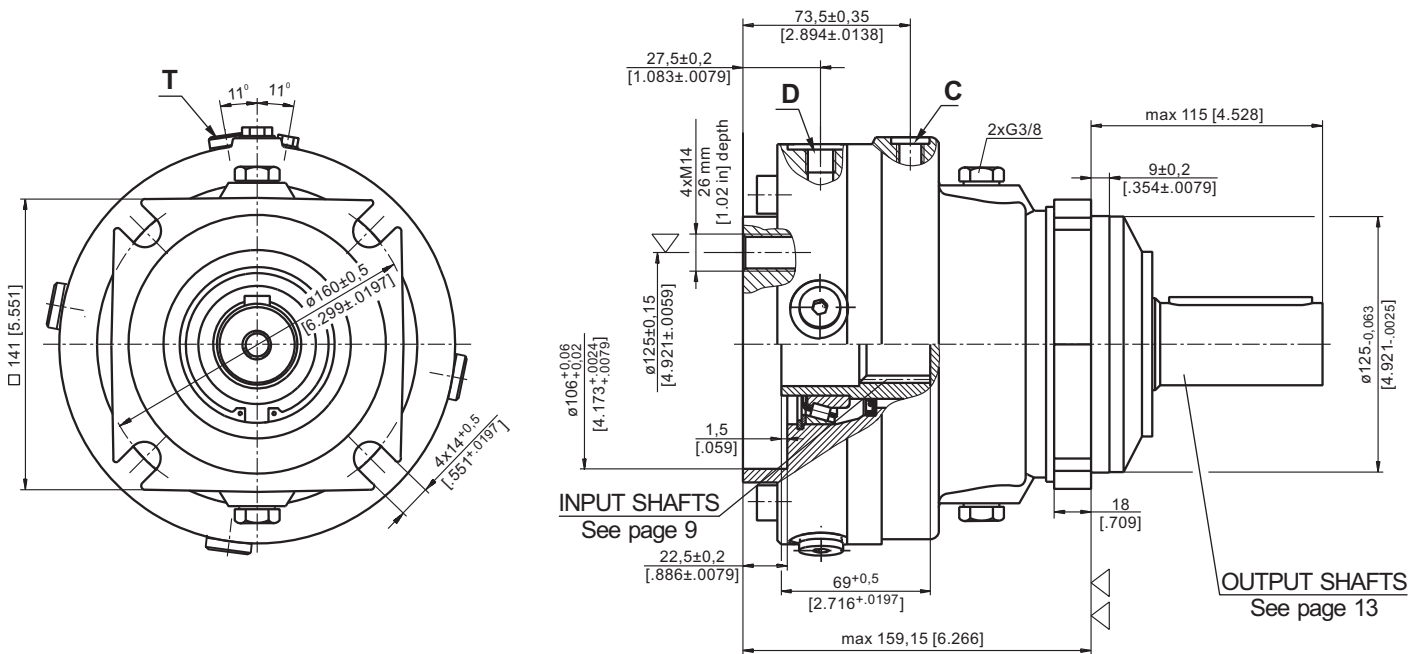

▽ - Place for attachment
(tightening torque for screw M14xL - 8.8 DIN 912,
11,5 daNm [1020 lb-in])

C: Brake release Port - G $\frac{1}{4}$, 9 mm [.35 in] depth
D: Drain plug for the Brake - G $\frac{1}{4}$, 9 mm [.35 in] depth
T: Drain plug for the Motor - G $\frac{1}{4}$, 9 mm [.35 in] depth

▽▽ - Place for attachment

**HYDRAULIC DISC BRAKES
FOR FLANGE ATTACHMENT TO MTS AND MTV HYDRAULIC MOTORS**

TYPE LBS/315

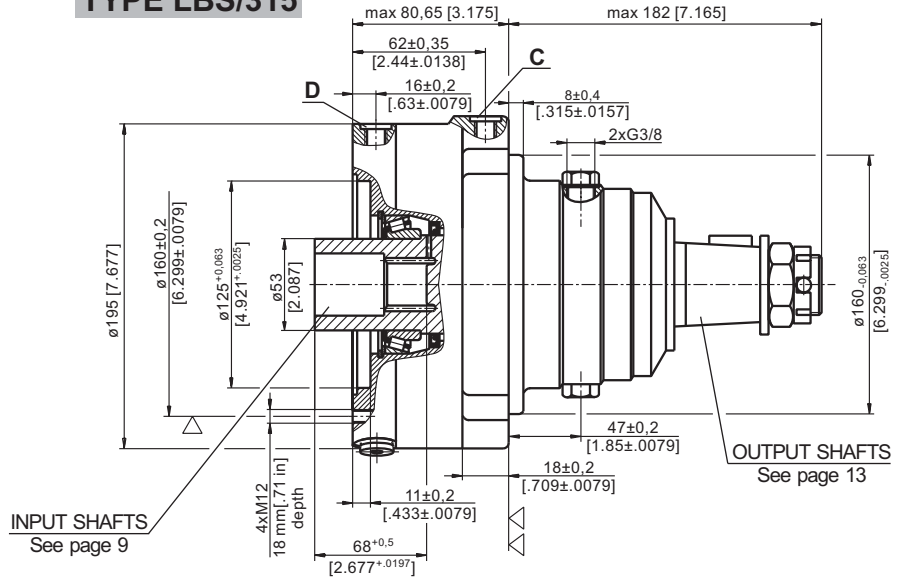
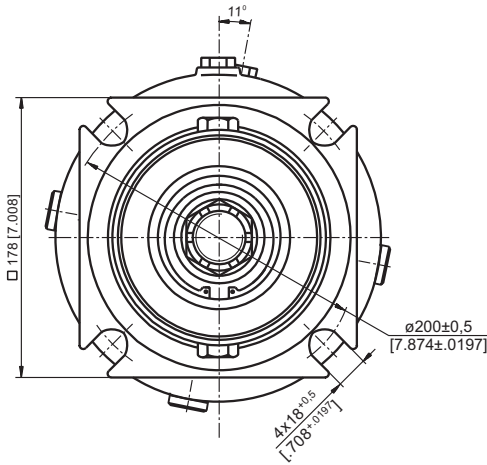

- ▽ - Place for attachment (tightening torque for screw M12x30- 8.8 DIN 912, 7 daNm [620 lb-in])
- ▽▽ - Place for attachment

- C:** Brake release Port - G $\frac{1}{4}$, 12 mm [.47 in] depth
- D:** Drainage tap - G $\frac{1}{4}$, 12 mm [.47 in] depth

TYPE LBV/315

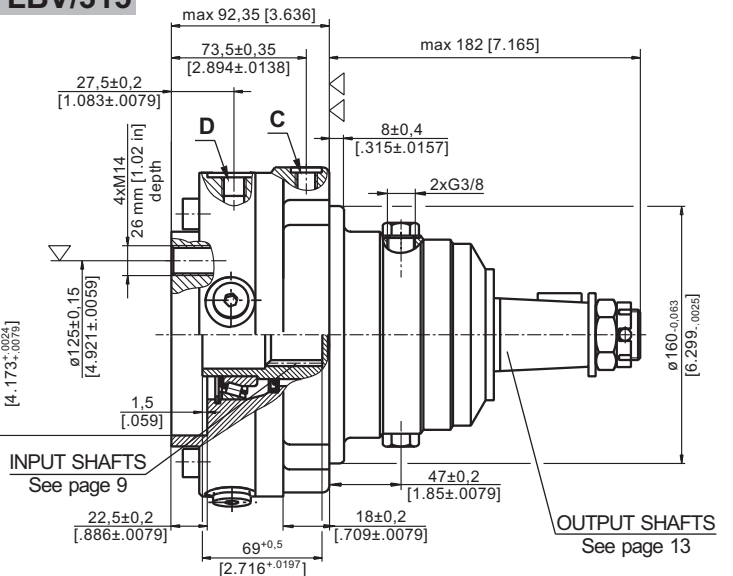
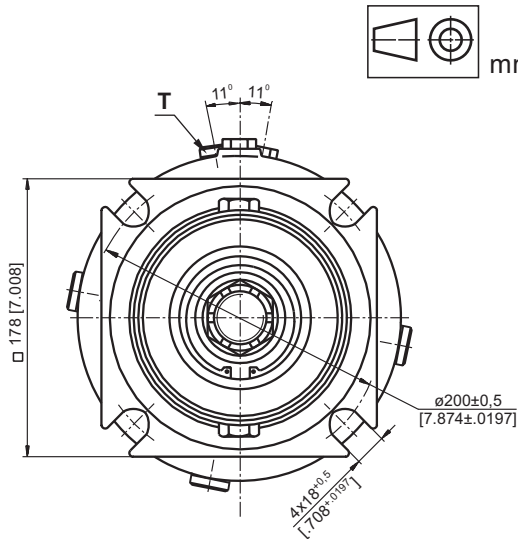

- ▽ - Place for attachment (tightening torque for screw M14xL - 8.8 DIN 912, 11,5 daNm [1020 lb-in])
- ▽▽ - Place for attachment

- C:** Brake release Port - G $\frac{1}{4}$, 9 mm [.35 in] depth
- D:** Drain plug for the Brake - G $\frac{1}{4}$, 9 mm [.35 in] depth
- T:** Drain plug for the Motor - G $\frac{1}{4}$, 9 mm [.35 in] depth

**INPUT FACE
For Versions 314 and 315**

TYPE LBS/314(315)

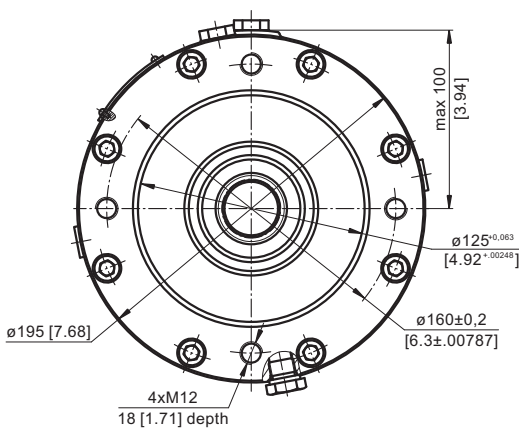

TYPE LBV/314(315)

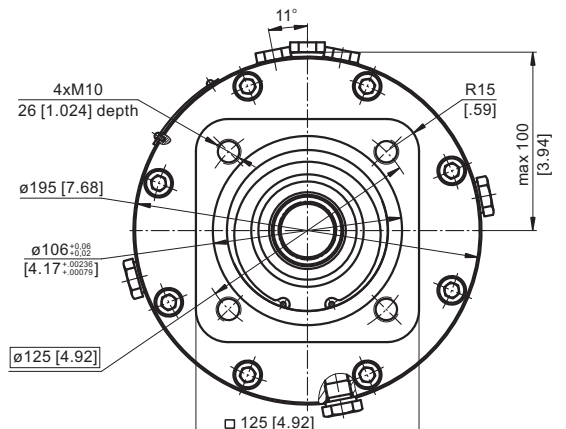

SPECIFICATION DATA

| Description | LBS/314,315 | 21 | 29 | 43 | 65 | 85 | 110 | 130 |
|--|------------------------------------|----------------------|----------------------|----------------------|----------------------|----------------------|-------------------------|--------------------------|
| *Min. Static Torque, daNm [lb-in] | | 18-23 [1593-2036] | 28-33 [2478-2921] | 42-46 [3717-4071] | 61-70 [5399-6196] | 83-92 [7346-8143] | 108-118 [9559-10444] | 126-136 [11152-12037] |
| Opening Pressure bar [PSI] | min** | 4-5 [58-72] | 6-7 [87-101] | 9-10 [130-145] | 13-15 [188-217] | 18-20 [261-290] | 23-25 [333-362] | 27-29 [391-420] |
| | max | 300 [4350] | | | | | | |
| Min. oil quantity for brake releasing | cm ³ [in ³] | 8-9 [.488-.549] | | | | | | |
| Oil volume | cm ³ [in ³] | 250 | | | | | | |
| Max. Pressure in drain space | bar [PSI] | 5 [72] | | | | | | |
| Weight for .../314 .../315 | kg [lb] | 24 [52.9] | | | | | | |
| | | 25 [55.1] | | | | | | |

*Static torque is obtained at working pressure - 0 bar.

**The indicated value is a difference between the inlet pressure for driving of the brake and the drain pressure.

Brakes must always have a drain line

LOAD CURVE

LBS(V) ... /314

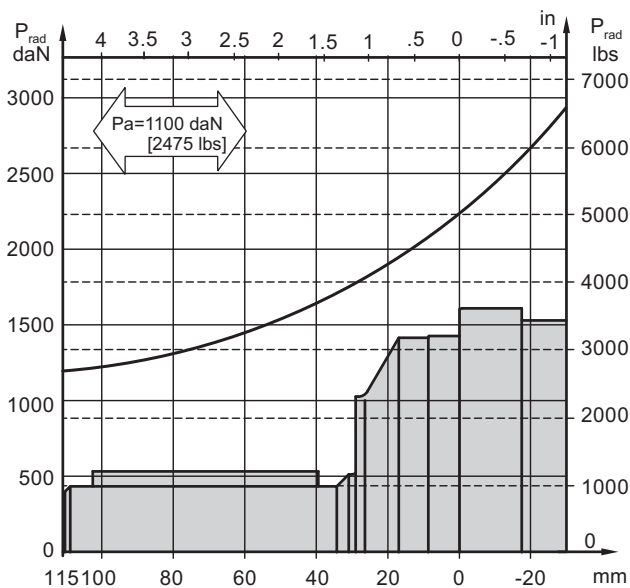

LBS(V) ... /315

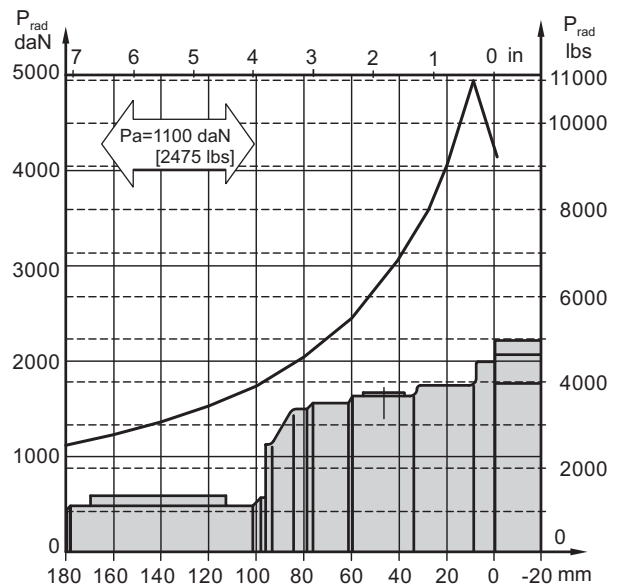

OUTPUT SHAFT EXTENSIONS

C - \varnothing 40 straight, Parallel key A12x8x70 DIN 6885
Max. Torque 132,8 daNm [11755 In-in]

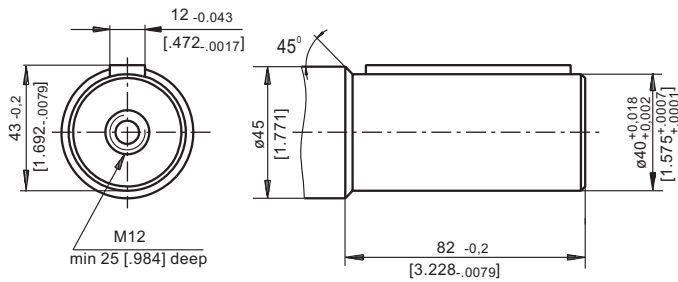

K -tapered 1:10, Parallel key B12x8x28 DIN 6885
Max. Torque 210,7 daNm [18650 lb-in]

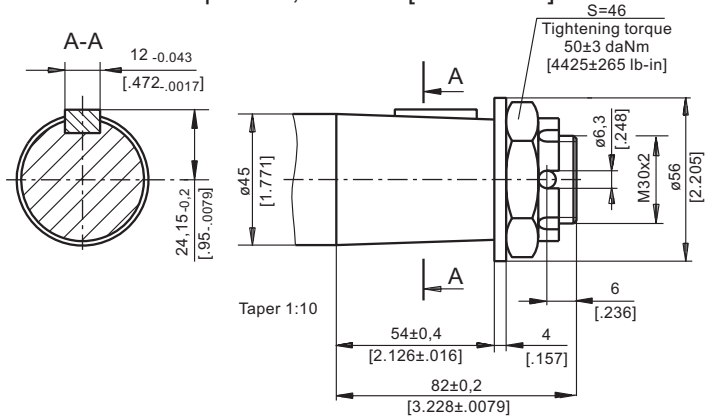

CO - \varnothing 1½" straight, Parallel key 3/8" x 3/8" x 2¼" BS46
Max. Torque 132,8 daNm [11755 In-in]

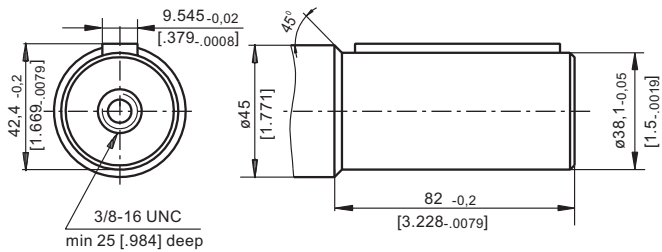

SH - \varnothing 1½" splined 17T, DP 12/24 ANSI B92.1-1976
Max. Torque 132,8 daNm [11755 In-in]

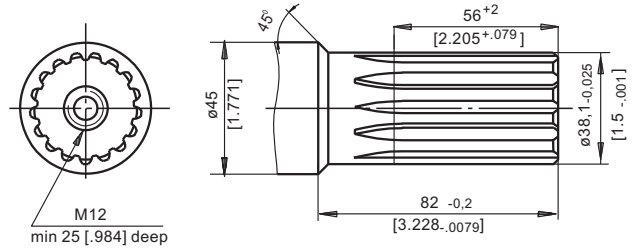

ORDER CODE

| | | | | | |
|----|---|---|---|---|---|
| 1 | 2 | 3 | 4 | 5 | 6 |
| LB | / | - | | | |

Pos.1 - Type

- S** - Disc Brake for short motor **S** - MTS
- V** - Disc Brake for very short motor **V** - MTV

Pos.2 - Design code

- 314** - for MTS and MTV Motors
- 315** - for MTS and MTV Motors (Wheel Mount)

Pos.3 - Static Torque code (See Specification data)

21, 29, 43, 65, 85, 110, 130

Pos.4 - Output Shaft Extensions*

- C** - \varnothing 40 straight, Parallel key A12x8x70 DIN 6885
- CO** - \varnothing 1½" straight, Parallel key 3/8" x 3/8" x 2¼" BS46
- SH** - \varnothing 1½" splined 17T, ANSI B92.1-1976
- K** - \varnothing 45 tapered 1:10, Parallel key B12x8x28 DIN6885

Pos.5 - Option (Paint)**

- omit - no Paint
- P** - Painted
- PC** - Corrosion Protected Paint

Pos.6 - Design Series

- omit - Factory specified

NOTES:

- * The permissible output torque for shafts must not be exceeded!
- ** The color is by customer's request.

The Disc Brakes are manganophosphatized as standard.

ATTENTION:

- Hydraulic brake is delivered without oil (it is lubricated only).
- Hydraulic brake is filled through the drain port **D**. Space is filled with 50 ÷ 120 cm³ [3.05÷7.32 in³] mineral oil HLP (DIN 51524) or HM (ISO 6743/4). For LB/288 fill oil after hydraulic motor assembly.
- In all brakes, friction discs and separators should be lubricated.

**HYDRAULIC DISC BRAKES
FOR FLANGE ATTACHMENT TO MVS HYDRAULIC MOTORS**

Type LBS/313

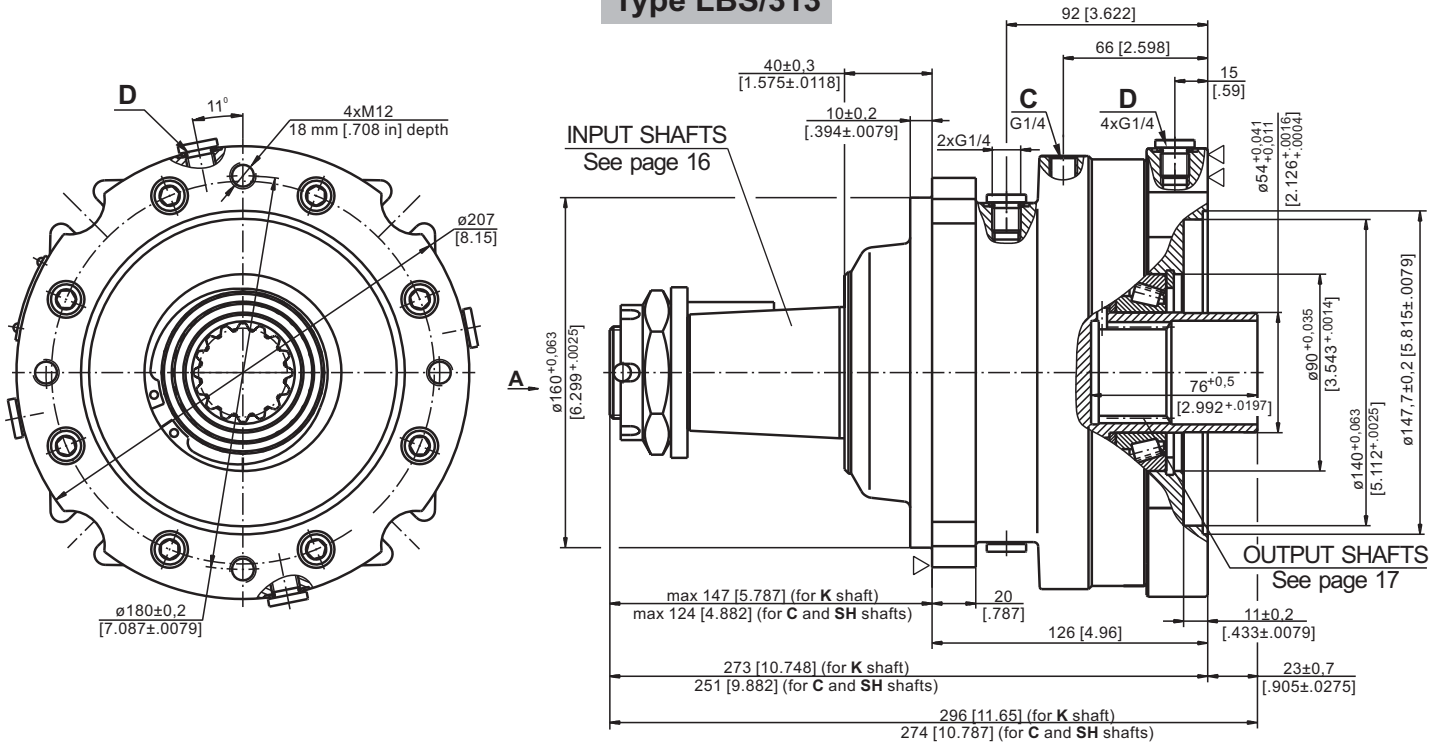

C: Brake release Port - G $\frac{1}{4}$, 12 mm [0.47 in] depth

D: Drainage tap - G $\frac{1}{4}$, 12 mm [0.47 in] depth

▽ - Place for attachment

▽▽ - Place for attachment
(tightening torque for screw M12x35 - 8.8 DIN 912,
7 daNm [620 lb-in])

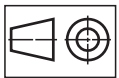

mm [in]

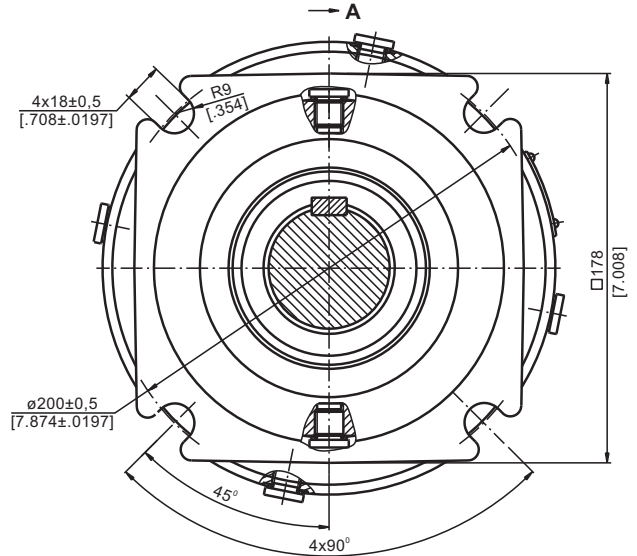

PERMISSIBLE SHAFT LOADS

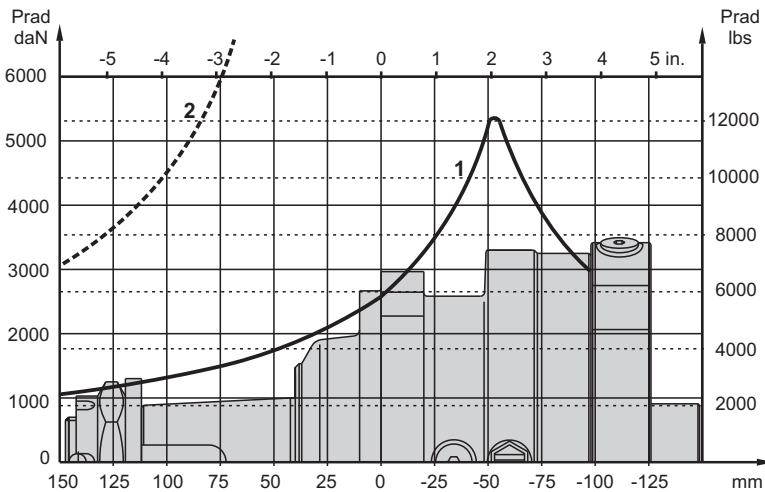

- 1 - Bearing curve:** The curve applies to a B10 bearing life of 3000 hours at 200 RPM.
- 2 - Shaft curve:** The curve represents Max. permissible radial shaft load with safety factor 3:1.

**HYDRAULIC DISC BRAKES
FOR FLANGE ATTACHMENT TO MVS HYDRAULIC MOTORS**

Type LBS/316

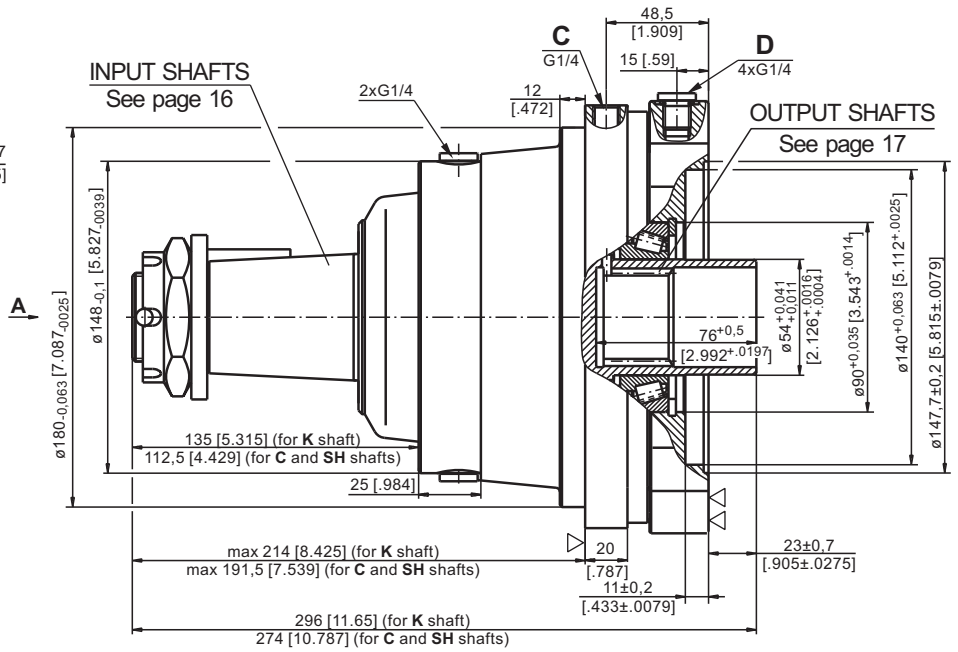
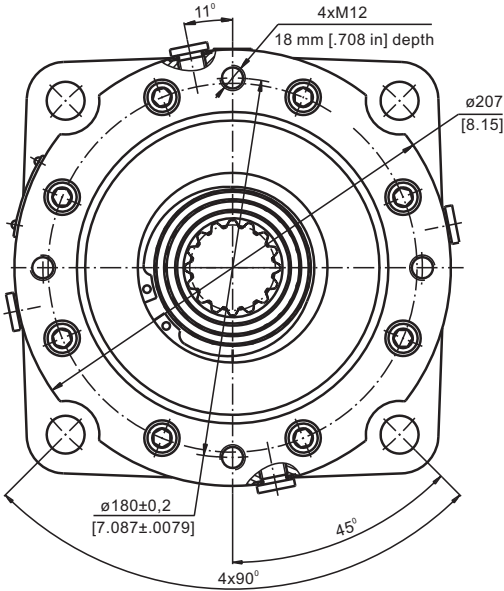

C: Brake release Port - G $\frac{1}{4}$, 12 mm [.47 in] depth

D: Drainage tap - G $\frac{1}{4}$, 12 mm [.47 in] depth

▽- Place for attachment

▽▽- Place for attachment
(tightening torque for screw M12x35 - 8.8 DIN 912,
7 daNm [620 lb-in])

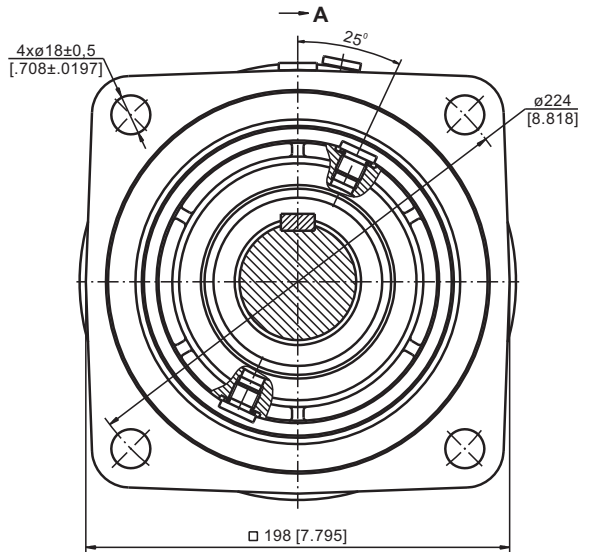

PERMISSIBLE SHAFT LOADS

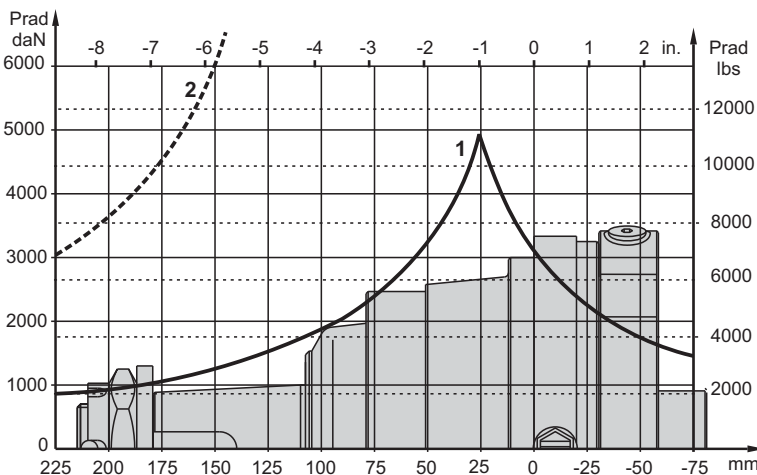

- 1 - Bearing curve:** The curve applies to a B10 bearing life of 3000 hours at 200 RPM.
- 2 - Shaft curve:** The curve represents Max. permissible radial shaft load with safety factor 3:1.

SPECIFICATION DATA

| Description LBS/313,316 | 21 | 29 | 43 | 65 | 85 | 110 | 130 |
|---|------------------------|----------------------|----------------------|----------------------|----------------------|-------------------------|--------------------------|
| *Min. Static Torque, daNm [lb-in] | 18-23 [1593-2036] | 28-33 [2478-2921] | 42-47 [3717-4160] | 61-71 [5399-6285] | 83-94 [7346-8320] | 108-118 [9559-10444] | 127-137 [11240-12125] |
| Opening Pressure min** bar [PSI] | 4-5 [58-72] | 6-7 [87-101] | 9-10 [130-145] | 13-15 [188-217] | 18-20 [261-290] | 23-25 [333-362] | 27-29 [391-420] |
| | max 300 [4350] | | | | | | |
| Min. oil quantity for brake releasing cm ³ [in ³] | 8 ÷ 9 [.488 ÷ .549] | | | | | | |
| Oil volume cm ³ [in ³] | 250 [15.25] | | | | | | |
| Max. Pressure in drain space bar [PSI] | 5 [72] | | | | | | |

*Static torque is obtained at working pressure - 0 bar.

**The indicated value is a difference between the inlet pressure for driving of the brake and the drain pressure.

Brakes must always have a drain line

SHAFT EXTENSIONS

C - ø50 straight, Parallel key A14x9x70 DIN 6885

SH - ø21/8"splined, 16 DP 8/16 ANS B92.1-1976

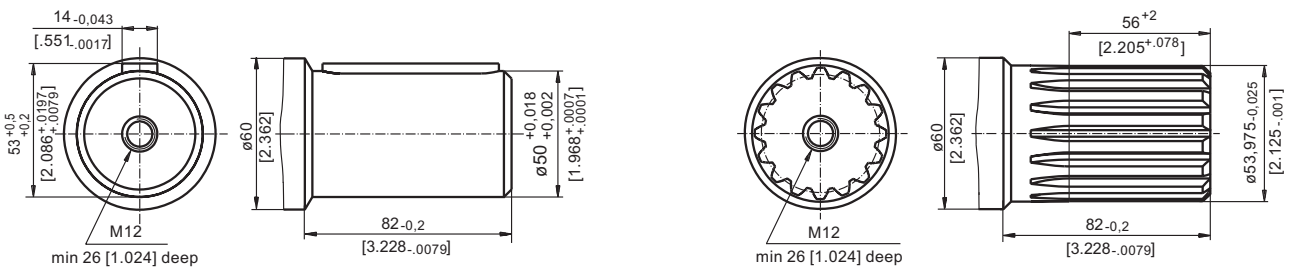

K -tapered 1:10, Parallel key B16x10x32 DIN 6885

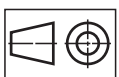
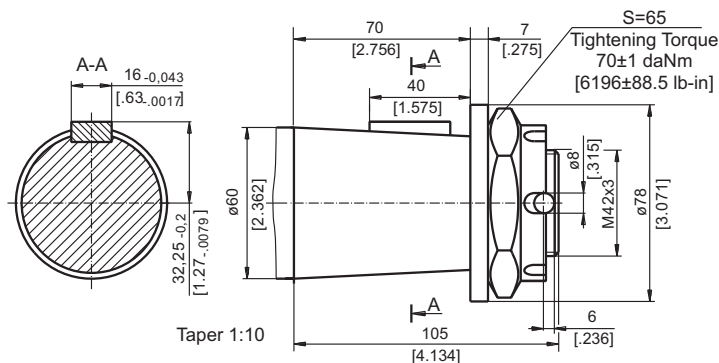

mm [in]

INTERNAL SPLINE DATA FOR THE ATTACHED COMPONENT

Standard ANS B92.1-1970, class 5
[$m=2.54$; corrected $x.m=+1,0$]

| Fillet Root Side Fit | | mm | inch |
|----------------------------------|-----------------|------------------------|---------------|
| Number of Teeth | z | 16 | 16 |
| Diametral Pitch | DP | 10/20 | 10/20 |
| Pressure Angle | | 30° | 30° |
| Pitch Dia. | D | 40,640 | 1.6 |
| Major Dia. | D _{ri} | 45,2 ^{+0,4} | 1.796÷1.780 |
| Minor Dia. | D _i | 38,5 ^{+0,039} | 1.5175÷1.516 |
| Space Width [Circular] | L _o | 5,18±0,037 | .2055±.2025 |
| Fillet Radius | R | 0,4 | .015 |
| Max. Measurement between Pins | L | 32,47 ^{+0,15} | 1.284±1.278 |
| Pin Dia. | d | 5,6±0,001 | .22051±.22043 |

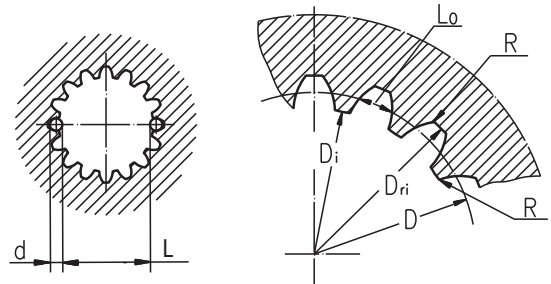

Hardening Specification:
HV=750±50 on the surface.
HV=560 at 0,7±0,2 mm [.035±.019in] case depth
Material: 20 MoCr4 EN 10084 or better.

ORDER CODE

| | 1 | 2 | 3 | 4 | 5 |
|------|---|---|---|---|---|
| LBS/ | | - | | | |

Pos.1 - Designe code

313 - for MVS Motors

316 - for MVS Motors (Wheel mount)

Pos.2 - Static Torque code (See Specification data)

21, 29, 43, 65, 85, 110, 130

Pos.3 - Output Shaft Extensions*

C - ø50 straight, Parallel key A14x9x70 DIN6885

SH - ø2 1/8" splined, ANSI B92.1-1976

K - ø60 tapered 1:10, Parallel key B16x10x32 DIN6885

Pos.4 - Option (Paint)**

omit - no Paint

P - Painted

PC - Corrosion Protected Paint

Pos.5 - Design Series

omit - Factory specified

NOTES:

* The permissible output torque for shafts must be not exceeded!

** The color is by customer's request.

The Disc Brakes are mangano-phosphatized as standard.

ATTENTION:

1. Hydraulic brake is delivered without oil (it is lubricated only).

2. In all brakes, friction discs and separators should be lubricated. Space is filled with 150 ÷ 300 cm³ [9.15 ÷ 18.3 in³] mineral oil HLP (DIN 51524) or HM (ISO 6743/4).

HYDRAULIC DISC BRAKES B...R- Wet

B...R brake is designed to be mounted to the wheels of low-speed agricultural and construction vehicles.

The advantage of these brakes is that despite the smallest possible dimensions they preserve long-term life of the bearings at high radial shaft load.

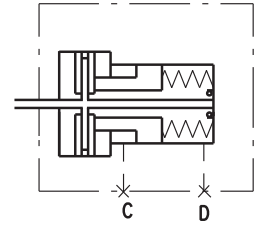

SPECIFICATION DATA

| Type | B35R | B55R |
|---------------------------------------|------------|------------|
| Static Torque of Brake, daNm [lb-in]* | 35 [3100] | 55 [4870] |
| Initial Release Pressure, bar [PSI] | 16 [232] | 16 [232] |
| Full Release Pressure, bar [PSI] | 19 [275] | 19 [275] |
| Max. Operating Pressure, bar [PSI] | 240 [3480] | 240 [3480] |
| Max. Speed, RPM | 90 | 90 |
| Cont. Radial Shaft Load daN [lbs]** | 500 [1125] | 500 [1125] |
| Max. Radial Shaft Load daN [lbs]*** | 700 [1575] | 900 [2030] |

* At 0 bar [0 PSI] back pressure

** At radial shaft load of 500 daN [1125 lbs], applied at center-line of the key and speed of rotation 90 RPM, the bearing life is 1000 hours.

*** The permissible values of radial shaft load may occur for max. 10% of every minute

DIMENSIONS AND MOUNTING DATA

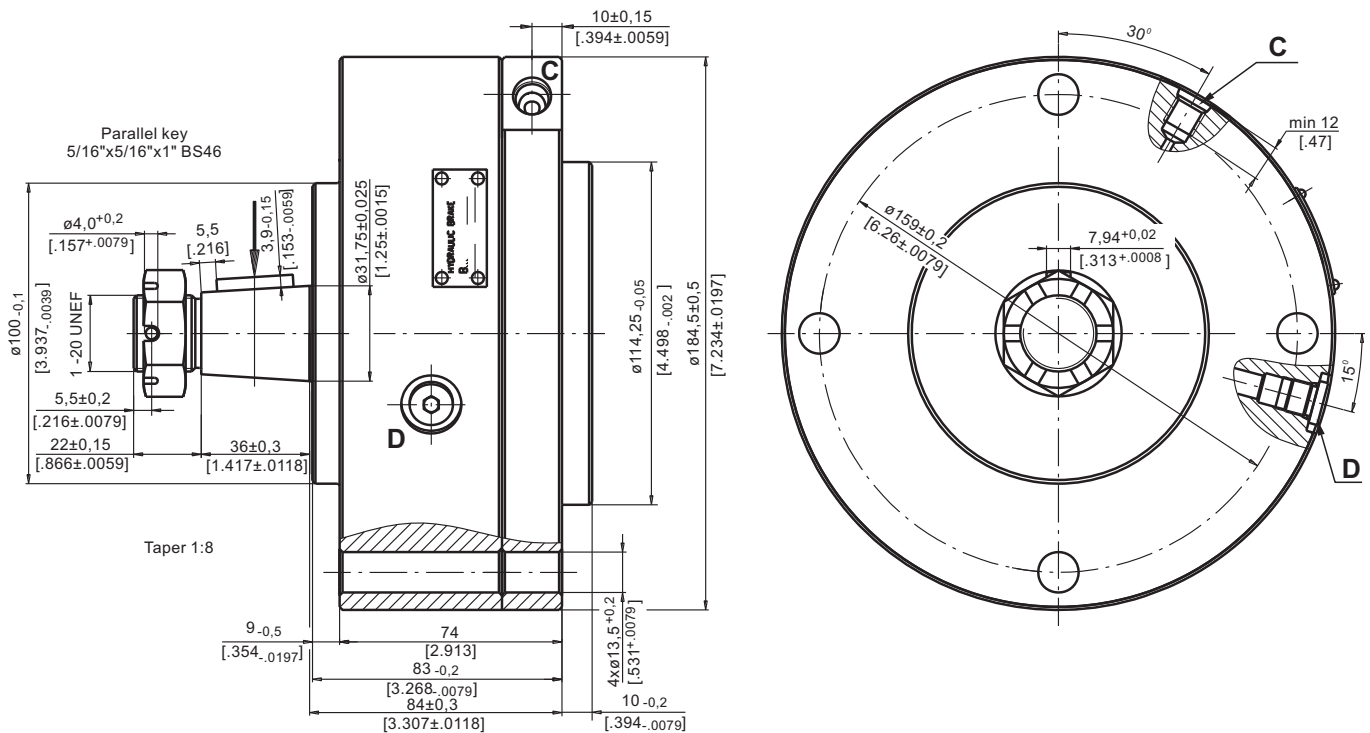

C : Brake Release Port -7/16-20 UNF
SAE J1926-1/ISO 11926-1

D : Drainage Tap - 7/16-20 UNF



HYDRAULIC DISC BRAKES B...T- Wet

B..T brake is designed to be mounted to the wheels of low-speed agricultural and construction vehicles.

The advantage of these brakes is that despite the smallest possible dimensions they preserve long-term life of the bearings at high radial shaft load.

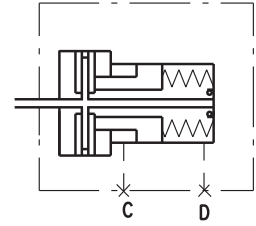

SPECIFICATION DATA

| Type | B50T | B55T | B60T | B65T | B85T |
|---------------------------------------|-------------|-------------|-------------|-------------|-------------|
| Static Torque of Brake, daNm [lb-in]* | 50 [4425] | 55 [4870] | 60 [5310] | 65 [5750] | 85 [7525] |
| Initial Release Pressure, bar [PSI] | 16 [232] | 16 [232] | 16 [232] | 17 [246] | 18 [260] |
| Full Release Pressure, bar [PSI] | 19 [275] | 19 [275] | 19 [275] | 20 [290] | 22 [320] |
| Max. Operating Pressure, bar [PSI] | 240 [3480] | 240 [3480] | 240 [3480] | 240 [3480] | 240 [3480] |
| Max. Speed, RPM | 60 | 60 | 60 | 60 | 60 |
| Cont. Radial Shaft Load daN [lbs]** | 1000 [2250] | 1000 [2250] | 1000 [2250] | 1000 [2250] | 1500 [3370] |
| Max. Radial Shaft Load daN [lbs]*** | 2150 [4830] | 2150 [4830] | 2150 [4830] | 2150 [4830] | 2250 [5060] |

* At 0 bar [0 PSI] back pressure

** At radial shaft load of 1000 daN [2250 lbs], applied at center-line of the key and speed of rotation 60 RPM, the bearing life is 1000 hours.

*** The permissible values of radial shaft load may occur for max. 10% of every minute

DIMENSIONS AND MOUNTING DATA

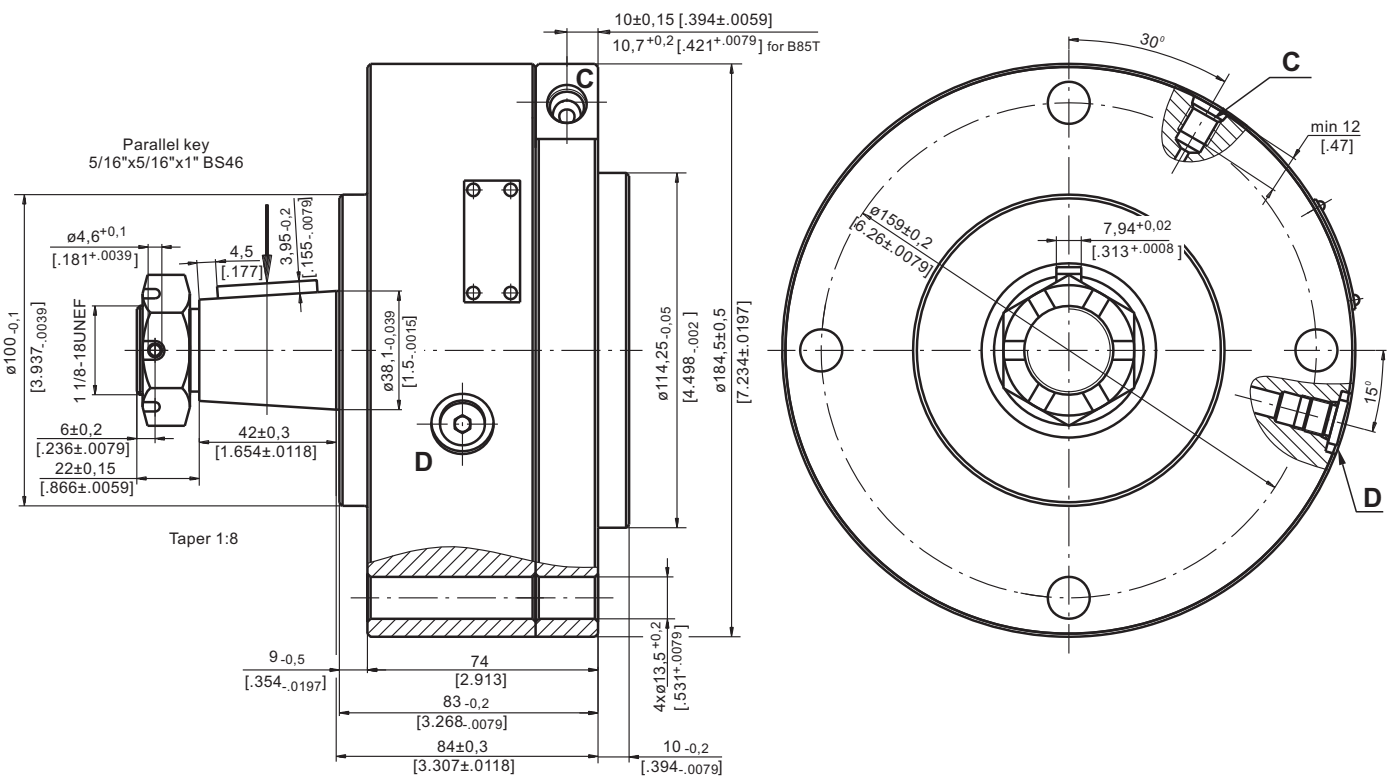

C : Brake Release Port - 7/16-20 UNF
SAE J1926-1/ISO 11926-1

D : Drainage Tap - 7/16-20 UNF



HYDRAULIC DISC BRAKES B130K...- Wet

This brake is designed to be mounted to the wheels of low-speed agricultural and construction vehicles.

The advantage of these brakes is that despite the smallest possible dimensions they preserve long-term life of the bearings at high radial shaft load.

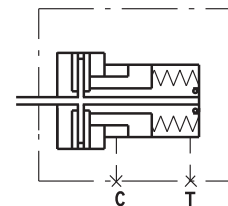

SPECIFICATION DATA

| Type | B130K |
|--|-----------------|
| Static Torque of Brake, daNm [lb-in]* | 143 [12565] |
| Min. Brake Release Pressure, bar [PSI] | 31-33 [119-478] |
| Max. Opening Pressure, bar [PSI] | 280 [4060] |
| Max. Permissible Pressure in Drain Line, bar [PSI] | 5 [72] |
| Weight, kg [lb] | 18,5 [40.8] |

* At 0 bar [0 PSI] back pressure

DIMENSIONS AND MOUNTING DATA

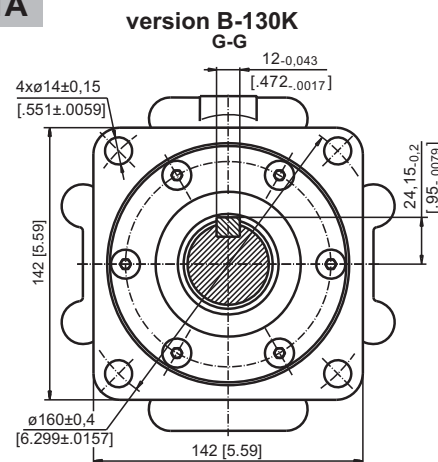
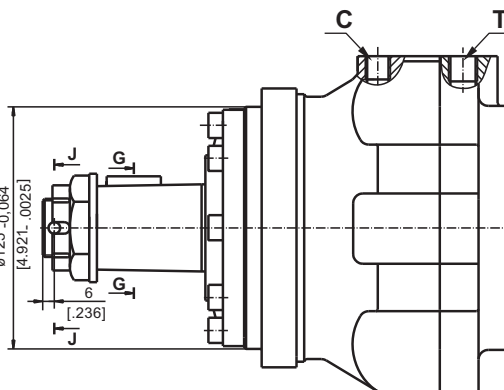
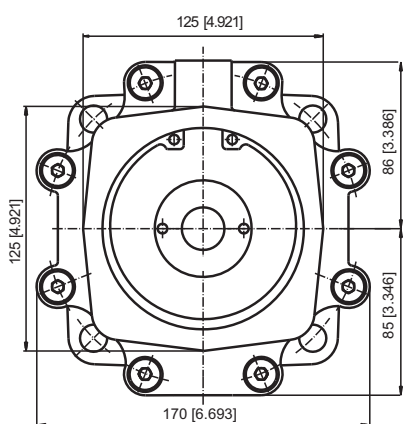

version B-130K

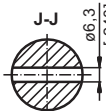

K -tapered 1:10,
Parallel key B12x8x28 DIN 6885
Max. Torque 210 daNm [18587 lb-in]

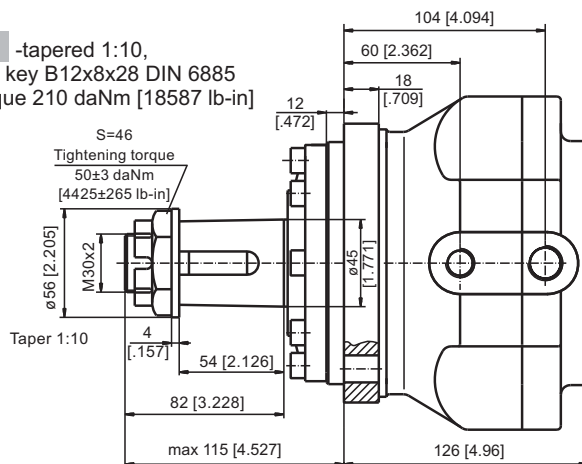

version B-130K-P

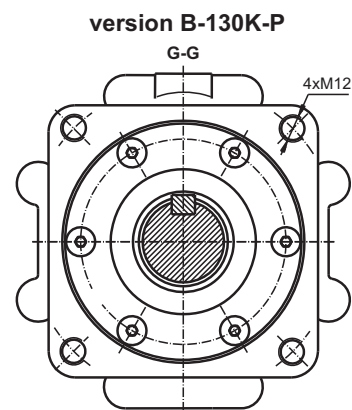
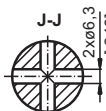

- C** - Brake release port, G1/4,
12 mm [0.472 in] depth
- D** - Drainage tap, G3/8,
13 mm [0.512 in] depth

PERMISSIBLE SHAFT LOADS

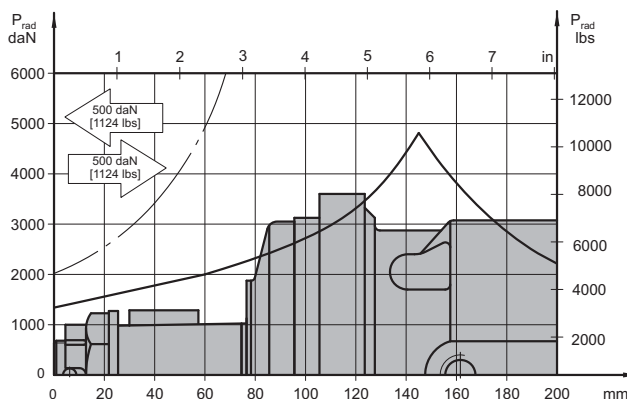

The curve applies to a B10 bearing life of 3000 hours at 200 RPM.

MOTOR-BRAKE SPECIAL FEATURES

| Special Feature Description | Order Code | Motor type | | | | |
|-----------------------------|------------|------------|------|-------|----|----|
| | | B/MR | MT/B | MTM/B | SW | TW |
| Low Leakage | LL | ○ | - | ○ | - | - |
| Low Speed Valving | LSV | ○ | - | ○ | - | - |
| Free Running | FR | - | - | ○ | | - |
| Reverse Rotation | R | ○ | ○ | ○ | - | - |
| Paint* | P | ○ | ○ | ○ | ○ | ○ |
| Corrosion Protected Paint* | PC | ○ | ○ | ○ | ○ | ○ |
| Special Paint** | PS | ○ | ○ | ○ | ○ | ○ |
| | PCS | | | | | |
| Check Valves | | S | S | - | S | S |

| | |
|----------|----------------|
| O | Optional |
| - | Not applicable |
| S | Standard |

* Colour at customer's request.

** Non painted feeding surfaces, colour at customer's request.

APPLICATION CALCULATION

VEHICLE DRIVE CALCULATIONS

1. Motor speed: n, RPM

$$n = \frac{2,65 \times v_{km} \times i}{R_m} \quad n = \frac{168 \times v_{mi} \times i}{R_{in}}$$

v_{km} - vehicle speed, km/h;

v_{mi} - vehicle speed, mil/h;

R_m - wheel rolling radius, m;

R_{in} - wheel rolling radius, in;

i - gear ratio between motor and wheels.

If no gearbox, use $i=1$.

2. Rolling resistance: RR, daN [lbs]

The resistance force resulted in wheels contact with different surfaces:

$$RR = G \times \rho$$

G - total weight loaded on vehicle, daN [lbs];

ρ - rolling resistance coefficient (Table 1).

Table 1

| Rolling resistance coefficient In case of rubber tire rolling on different surfaces | |
|--|-------------|
| Surface | ρ |
| Concrete- faultless | 0.010 |
| Concrete- good | 0.015 |
| Concrete- bad | 0.020 |
| Asphalt- faultless | 0.012 |
| Asphalt- good | 0.017 |
| Asphalt- bad | 0.022 |
| Macadam- faultless | 0.015 |
| Macadam- good | 0.022 |
| Macadam- bad | 0.037 |
| Snow- 5 cm | 0.025 |
| Snow- 10 cm | 0.037 |
| Polluted covering- smooth | 0.025 |
| Polluted covering- sandy | 0.040 |
| Mud | 0.037÷0.150 |
| Sand- Gravel | 0.060÷0.150 |
| Sand- loose | 0.160÷0.300 |

3. Grade resistance: GR, daN [lbs]

$$GR = G \times (\sin \alpha + \rho \times \cos \alpha)$$

α - gradient negotiation angle (Table 2)

Table 2

| Grade % | α Degrees | Grade % | α Degrees |
|---------|------------------|---------|------------------|
| 1% | 0° 35' | 12% | 6° 5' |
| 2% | 1° 9' | 15% | 8° 31' |
| 5% | 2° 51' | 20% | 11° 19' |
| 6% | 3° 26' | 25% | 14° 3' |
| 8% | 4° 35' | 32% | 18° |
| 10% | 5° 43' | 60% | 31° |

4. Acceleration force: FA, daN [lbs]

Force FA necessary for acceleration from 0 to maximum speed v and time t can be calculated with a formula:

$$FA = \frac{v_{km} \times G}{3,6 \times t}, [daN] \quad FA = \frac{v_{mi} \times G}{22 \times t}, [lbs];$$

FA - acceleration force, daN [lbs];

t - time, [s].

5. Tractive effort: DP, daN [lbs]

Tractive effort DP is the additional force of trailer. This value will be established as follows:

-acc.to constructor's assessment;

-as calculating forces in items 2, 3 and 4 of trailer; the calculated sum corresponds to the tractive effort requested.

6. Total tractive effort: TE, daN [lbs]

Total tractive effort TE is total effort necessary for vehicle motion; that the sum of forces calculated in items from 2 to 5 and increased with 10 % because of air resistance.

$$TE = 1,1 \times (RR + GR + FA + DP)$$

RR - force acquired to overcome the rolling resistance;

GR - force acquired to slope upwards;

FA - force acquired to accelerate (acceleration force);

DP - additional tractive effort (trailer).

7. Motor Torque moment: M, daNm [lb-in]

Necessary torque moment for every hydraulic motor:

$$M = \frac{TE \times R_m [R_{in}]}{N \times i \times \eta_m}$$

N - motor numbers;

η_m - mechanical gear efficiency (if it is available).

8. Cohesion between tire and road covering: M_w, daNm [lb-in]

$$M_w = \frac{G_w \times f \times R_m [R_{in}]}{i \times \eta_m}$$

To avoid wheel slipping, the following condition should be observed $M_w > M$

f - frictional factor;

G_w - total weight over the wheels, daN [lbs].

Table 3

| Surface | Frictional factor f |
|---------------------------------|---------------------|
| Steel on steel | 0.15 ÷ 0.20 |
| Rubber tire on polluted surface | 0.5 ÷ 0.7 |
| Rubber tire on asphalt | 0.8 ÷ 1.0 |
| Rubber tire on concrete | 0.8 ÷ 1.0 |
| Rubber tire on grass | 0.4 |

9.Radial motor loading: P_{rad} , daN [lbs]

When motor is used for vehicle motion with wheels mounted directly on motor shaft, the total radial loading of motor shaft P_{rad} is a sum of motion force and weight force acting on one wheel.

- G_w - Weight held by wheel;
- P_{rad} - Total radial loading of motor shaft;
- M/R - Motion force.

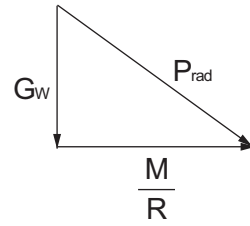

$$P_{rad} = \sqrt{G_w^2 + \left(\frac{M}{R}\right)^2}$$

In accordance with calculated loadings the suitable motor from the catalogue is selected.

DRAINAGE SPACE AND DRAINAGE PRESSURE

Advantages in oil drainage from drain space: Cleaning; Cooling and Seal lifetime prolonging.

