

VALVE BLOCKS FOR HKU AND XY TYPE BKH...

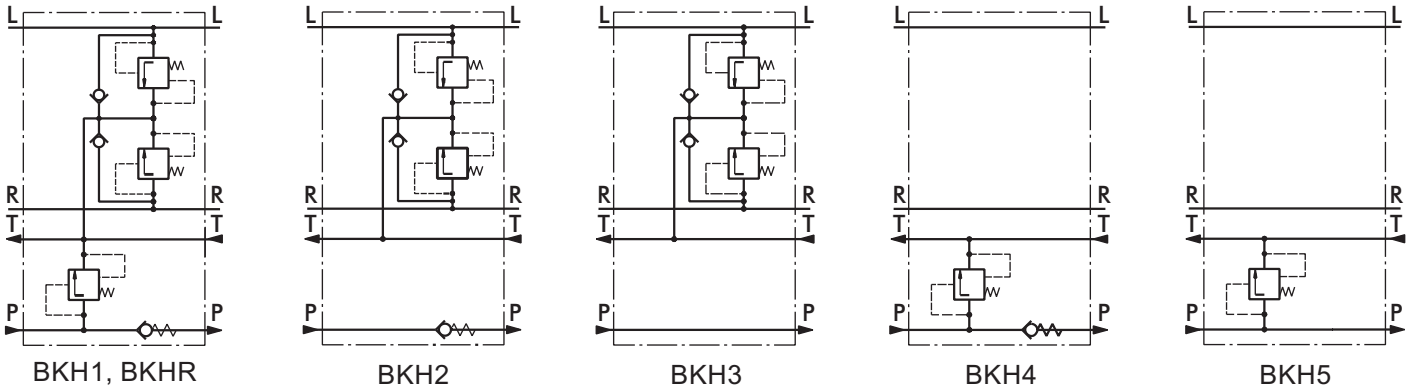

The M+S Hydraulic BKH valves are developed to protect the components of the hydraulic circuit: pumps, steering units and cylinders - from overloads, impacts and cavitation. Some of their advantages are: easy integration into any hydraulic circuit, easy mounting to the steering unit, and quick and easy hose connections. Depending on the design and the built in valves the BKH valves can be divided into 6 types: BKH1 ... BKH5 and BKHR, with BKH5 designed for XY steering units only. The maximum flow rate is in compliance with the whole range of HKU and XY steering units but no more than 80 l/min. The pressure settings for the entry relief valves and the shock valves are presented in the table.



SPECIFICATION DATA

Parameters	Type										
	BKH1, BKHR				BKH2	BKH3	BKH4, BKH5				
Rated Flow	lpm	80									
	[GPM]	[21.1]									
Rated Pressure	bar	160									
	[PSI]	[2320]									
Relief Valve Pressure Settings*	bar	80	100	125	150	-	-	80	100	125	150
	[PSI]	[1160]	[1450]	[1810]	[2175]			[1160]	[1450]	[1810]	[2175]
Shock Valves Pressure Settings**	bar	140	160	180	200	200	240	-	-	-	-
	[PSI]	[2030]	[2320]	[2610]	[2900]	[2900]	[3480]				
Weight	kg	1,8 , 2,3				1,8		1,8			
	[lb]	[4.0] , [5.1]				[4.0]		[4.0]			

* Pressure Settings are at flow rate of 30 lpm [7.92 GPM] and viscosity 21 mm²/s [105 SUS] at 50° C [122°F].

** Pressure Settings are at flow rate of 2 lpm [.53 GPM] and viscosity 21 mm²/s [105 SUS] at 50° C [122°F].

DIMENSIONS AND MOUNTING DATA - BKH1, 2, 3, 4

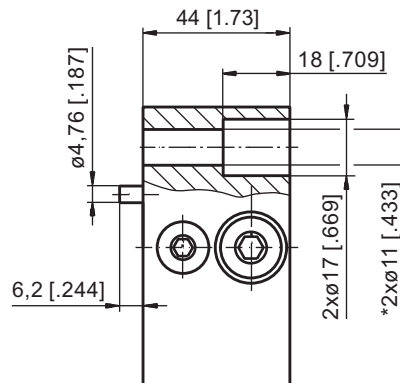
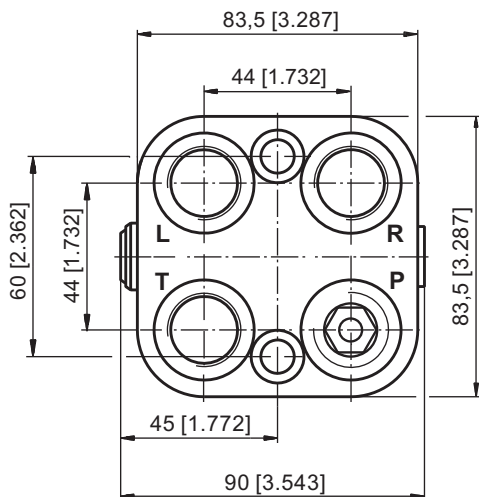

Code	Ports - P, T, R, L Thread
-	G1/2 20 [.80] depth
M	M22x1,5 20 [.80] depth
A	3/4 - 16 UNF O-ring 20 [.80] depth

* Connection to the HKU is done with 2 screws M10x1x40 -8.8 DIN 912 or with 2 screws 3/8-24 UNF ANSI B18.3-76, long 1.5". Tightening torque: 2,5±0,5 daNm [177±265 lb-in].

DIMENSIONS AND MOUNTING DATA - BKHR

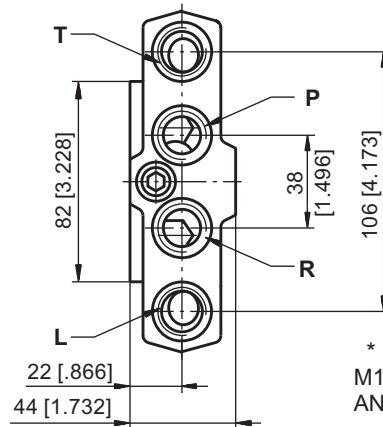
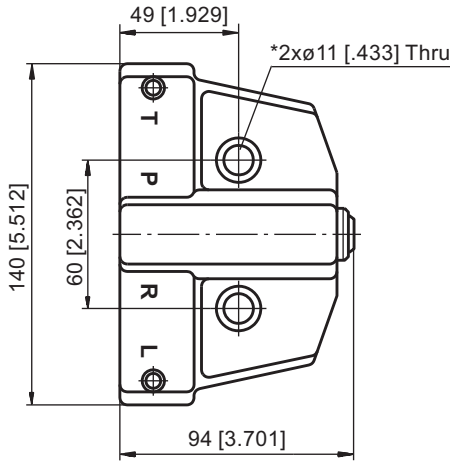

Code	Ports - P, T, R, L Thread
M	M18x1,5 22 [.87] depth
A	3/4 - 16 UNF O-ring 22 [.87] depth

* Connection to the HKU is done with 2 screws M10x1x40 -8.8 DIN 912 or with 2 screws 3/8-24 UNF ANSI B18.3-76, long 1.5".
Tightening torque: 2,5±0,5 daNm [177÷265 lb-in].

DIMENSIONS AND MOUNTING DATA - BKH5

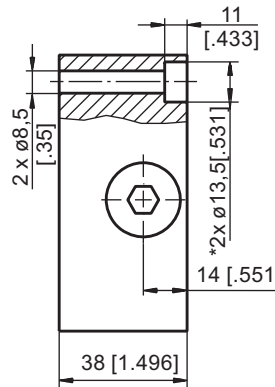
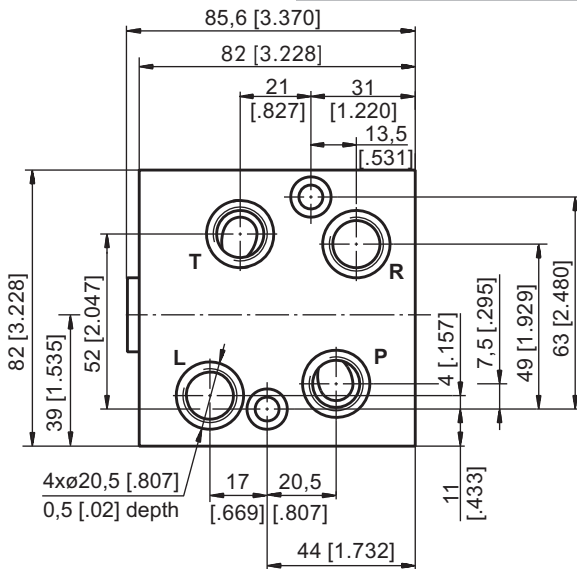

Code	Ports - P, T, R, L Thread
M	M16x1,5 14 [.55] depth

* Connection to the XY is done with 2 screws M8x1x40 -8.8 DIN 912. Tightening torque: 2,5±0,5 daNm [177÷265 lb-in].

ORDER CODE

	1	2	3	4	5
BKH		-	-		

Pos.1 - Versions*

R	1	2	3	4	5	
•	•			•	•	- Input relief valve on line "P"
•	•	•		•		- Input check (non-return) valve on line "P"
•	•	•	•			- Shock valves on lines "R" and "L"
•	•	•	•			- Anti-cavitation valves on lines "R" and "L"

Pos.2 - Relief Valve Pressure Settings, bar**

80	100	125	150
-----------	------------	------------	------------

Pos.3 - Ports***

- omit - BSPP (ISO 228)
- A** - SAE (ANSI B 1.1 - 1982)
- M** - Metric (ISO 262)

Pos.4 - Options (Paint)****

- omit - No Paint
- P** - Painted
- PC** - Corrosion Protected Paint

Pos.5 - Design Series

- omit - Factory specified

Notes: * Versions **R, 1, 2, 3, 4** - for **HKU**; **5** - for **XY**.
** That does not concern version **2** and **3**.
*** For Port size see drawings on page 19 and 20.
**** Colour at customer's request.

The valve blocks are mangano-phosphatized as standard.

GENERAL APPLICATION AND SPECIFICATION INFORMATION

APPLICATION

(SIZING AND STEERING SYSTEM DESIGN PROCESS)

STEP ONE:

Calculate approximate kingpin torque (M_L).

$$M_L = G \cdot \mu \sqrt{\frac{B^2}{8} + \ell^2}$$

Note: Double M_L if steered wheels are powered.

M_L = Kingpin torque in daNm [lb-in].

G = Vehicle weight on steered axle daN [lbs] (use maximum estimated overload weight).

μ = Coefficient of friction (use Chart № 1, dimensionless) determined by ℓ/B (see Diagram № 1).

B = Nominal width of tyre print, m [in] (see Diagram № 1).

ℓ = Kingpin offset. The distance between tyre centerline intersection at ground and kingpins centerline intersection at ground in, m [in] (see Diagram № 1).

Chart № 1

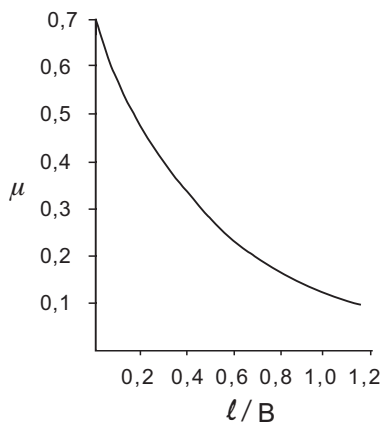

Rubber tyres on dry concrete.

Diagram № 1

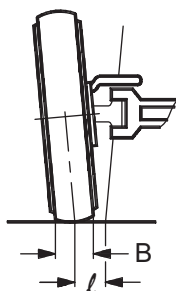
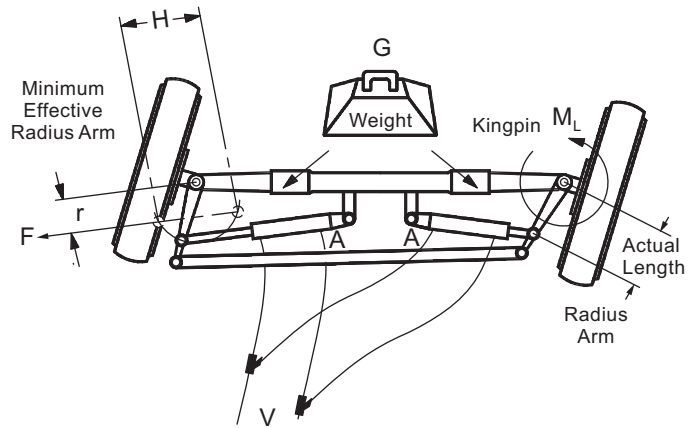

Diagram № 2



STEP TWO:

Calculate approximate cylinder; force-area-stroke-volume.

FORCE
$$F = \frac{M_L}{r}$$

F = Force required daN [lbs] to steer axle.

M_L = Kingpin torque in daNm [lb-in] from step one. Double M_L if steered wheels are powered.

r = Effective radius Arm mm [in] is the minimum distance from the centerline of the cylinders minimum and maximum stroke points parallel to the kingpin center pivot. This is not the physical length of the radius Arm (see Diagram № 2 and Chart № 2).

Chart № 2

$$r_{\min.} = r_{\max.} \cdot \cos \frac{\gamma}{2}$$

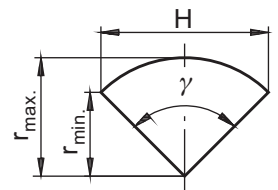

STROKE

H = Stroke, cm [in].

Calculate stroke of cylinder using Diagram № 2 and Chart № 2 as shaft.

$$H = 2 r_{\max.} \cdot \sin \frac{\gamma}{2}$$

AREA

$$A = \frac{F}{\Delta P}$$

A = Cylinder area for axle cylinder set, cm^2 [in²].

F = Force required from step two force formula, daN [lbs].

ΔP = Hydraulic pressure bar [PSI] use following percentage of relief valve setting by amount of load on steered axle. Severe load 25% - medium load 55% - no load 75%.

DIAMETER

After the cylinder set area is determined, the cylinder diameter can be calculated.

D = Inside diameter of cylinder, cm [in].
d = Road diameter of cylinder, cm [in].

Choose type of cylinder arrangement and formula shown for that type.

Differential Cylinder

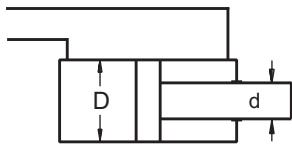

$$D = \sqrt{\frac{4A}{\pi} + d^2}$$

Note: $\left(\frac{d}{D}\right)^2 \leq 0,15$

Cross Connected Cylinders

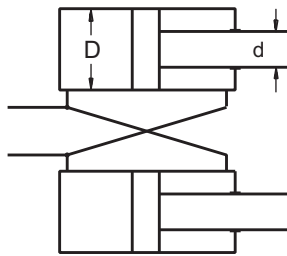

$$D = \sqrt{\frac{2A}{\pi} + \frac{d^2}{2}}$$

Balanced Cylinder

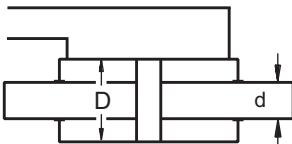

$$D = \sqrt{\frac{4A}{\pi} + d^2}$$

Opposed Cylinder

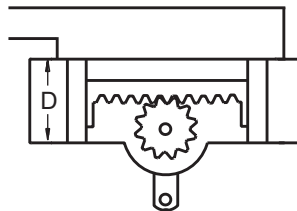

$$D = \sqrt{\frac{4A}{\pi}}$$

VOLUME $V = H \cdot A$

V = Volume. The total amount of oil required to move the cylinder rod(s) through the entire stroke, cm³ [in³].

H = Stroke, cm [in].

A = Area, cm² [in²].

Note: For differential cylinders it is important to calculate average cylinder volume for step three using below formula.

$$V_{avg.} = H \cdot \frac{\pi}{4} (2 \cdot D^2 - d^2)$$

STEP THREE:

Selecting displacement of hydrostatic steering unit.

At this point determine number of steering wheel revolutions desired for your application to steer the wheels from one side to the other (lock to lock). Depending on the type of vehicle and its use, this will vary from 3 to 5 turns.

DISPLACEMENT $V_D = \frac{V}{n}$

V_D = Displacement, cm³/rev [in³/rev].

V = Volume of oil, cm³ [in³].

n = Steering wheel turns lock to lock.

After completing the above displacement calculation, choose the closest standard hydrostatic steering unit in displacement size that incorporates circuitry you require.

Recalculate the number of steering wheel turns using the displacement of selected standard hydrostatic steering unit outlined above. Use the formula shown below.

$$n = \frac{V}{V_D}$$

V = Volume of oil, cm³ [in³].

n = Steering wheel turns lock to lock.

Note: For differential cylinders applications the cylinder volume will be different for left and right turns - this means the value n (steering wheel turns lock to lock) will vary when turning to the left or right.

STEP FOUR:

Calculate approximate minimum and maximum steering circuit flow requirements.

$$Q = \frac{V_D \cdot N}{\text{Unit Conversion for Imperial or [1000] Metric}}$$

Q = Steering circuit flow, lpm [GPM].

V_D = Unit displacement, cm³/rev [in³/rev]

N = Steering wheel input speed, RPM.

Recommended steering speed is 50 to 100 RPM.

Many variables are involved in sizing the pump. We suggest that the manufacturer should test and evaluate for the desired performance.

GENERAL INFORMATION

FLUID DATA:

To insure maximum performance and life of the Hydrostatic steering units, use premium quality hydraulic oils. Fluids with effective quantities of anti-wear agents or additives are highly recommended. If using synthetic fluids consult the factory for alternative seal materials.

• **Viscosity**

Viscosity at normal operating temperature should be approx. 20 mm²/s [100 SUS]. Viscosity range 10 - 300 mm²/s [60 - 1500 SUS].

• **Temperature**

Normal operating temperature range from +30°C [+85°F] to +60°C [140°F].

Minimum operating temperature -40°C [-40°F].

Maximum operating temperature +80°C [+176°F].

Note: Extended periods of operation at temperature of 60°C and above will greatly reduce the life of the oil due to oxidation and will shorten the life of the product.

Filtration

The maximum degree of contamination per ISO 4406 or CETOP RP is:

- 20/17 open center units
- 19/16 closed center and load sensing
- 16/12 priority valves

Return line filtration of 25 μm nominal (40 - 50 μm absolute) or finer is recommended.

In extremely dusty conditions filtration of 10 μm absolute should be used.

START UP

All air must be purged from system before operating unit. It is extremely important that any external lines or units with load sensing or priority feature be completely bled. Lines going to and from cylinders as well as lines to and from pump be purged of all air. It is recommended that a 10-15 μm filter be used between pump and steering unit before start up.

MOUNTING UNITS

All hydrostatic steering units should be installed for ease of access. It is recommended that the steering unit be located outside the vehicle cabin.

It is important that no radial axial load be applied to the hydrostatic steering unit input shaft. Some or all radial and axial loads must be absorbed by the steering column or other operating devices supplied by the vehicle manufacturer.

Ports on the steering cylinder(s) should face upward to prevent damage.

During installation of the hydrostatic steering unit, cleanliness is of the utmost importance. Pipe plugs should be left in place during mounting and only removed when hydraulic lines are to be connected.

CONVERSIONS

to convert inches and millimeters:

- 1 in = 25,4 mm
- 1 mm = .03973 in

to convert gallons per minute and liters per minute:

- 1 GPM = 3,785 lpm
- 1 lpm = .2642 GPM

to convert pounds per square inch and bar:

- 1 PSI = 0,0689 bar
- 1 bar = 14.51 PSI

to convert pounds-inch and newton-meters:

- 1 lb-in = 0,113 Nm
- 1 Nm = 8.85 lb-in

TORQUE TIGHTENING VALUES

Fluid connections

Fluid connection	Max. tightening torque daNm [lb-in]			
	metal edge	copper washer	aluminum washer	O - ring
G 1/4	4,0 [350]	3,5 [309]	3,5 [309]	
G 3/8	7,0 [620]	4,5 [398]	5,0 [442]	
G 1/2	10,0 [885]	5,5 [486]	8,0 [708]	
G 3/4	18,0 [1593]	9,0 [796]	13,0 [1150]	
M 10 x 1	4,0 [350]	2,0 [180]	3,0 [265]	
M 18 x 1,5	8,0 [708]	5,5 [486]	7,0 [620]	
M 22 x 1,5	10,0 [885]	6,5 [575]	8,0 [708]	
7/16 - 20 UNF				2,0 [180]
9/16 - 18 UNF				5,0 [442]
3/4 - 16 UNF				6,0 [531]
7/8 - 14 UNF				9,0 [796]
1 1/16 - 12 UN				12,0 [1062]

Mounting bolts

Mounting bolts	Tightening torque daNm [lb - in]
3/8 - 16 UNC	3,0 ± 0,5 [230 ÷ 310]
M 10 x 1	6,5 ± 0,5 [540 ÷ 620]
M 10	3,0 ± 0,5 [230 ÷ 310]